

Description

The ACE24C16A provides low operation voltage of 16384 bits of serial electrically erasable and programmable read-only memory (EEPROM) organized as 2048 words of 8 bits each. The device is optimized for use in many industrial and commercial applications where low-power and low-voltage operations are essential.

Features

- Low Operation Voltage: Vcc=1.7V to 5.5V
- Internally Organized: 2048x8
- Two-wire Serial Interface
- Schmitt Trigger, Filtered Inputs for Noise Suppression
- Bi-directional Data Transfer Protocol
- 1MHz(2.5V~5.5V) and 400kHz(1.7V) Compatibility
- Write Protect Pin for Hardware Data Protection
- 16-byte Page Write Modes
- Partial Page Writes are Allowed
- Self-timed Write Cycle (5 ms max)
- High-reliability - Endurance: 1,000,000 Write Cycles
- Data Retention: 100 Years

Absolute Maximum Ratings

Operating Temperature	-55°C to +125°C
Storage Temperature	-65°C to +150°C
Voltage on Any Pin with Respect to Ground	-1.0V to +7.0V
Maximum Operating Voltage	6.25V
DC Output Current	5.0 mA

*Notice: Stresses beyond those listed under "Absolute Maximum Ratings" may cause permanent damage to the device. This is a stress rating only and functional operation of the device at these or any other conditions beyond those indicated in the operational sections of this specification are not implied. Exposure to absolute maximum rating conditions for extended periods may affect device reliability.

Packaging Type

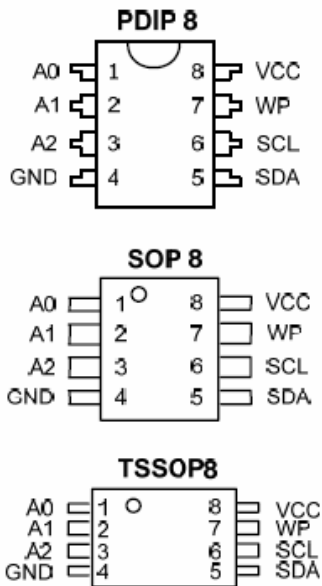

Pin Configurations

Pin Name	Function
A0~A2	Device Address Inputs
SDA	Serial Data Input / Output
SCL	Serial Clock Input
WP	Write Protect
VCC	Power Supply
GND	Ground

Block Diagram

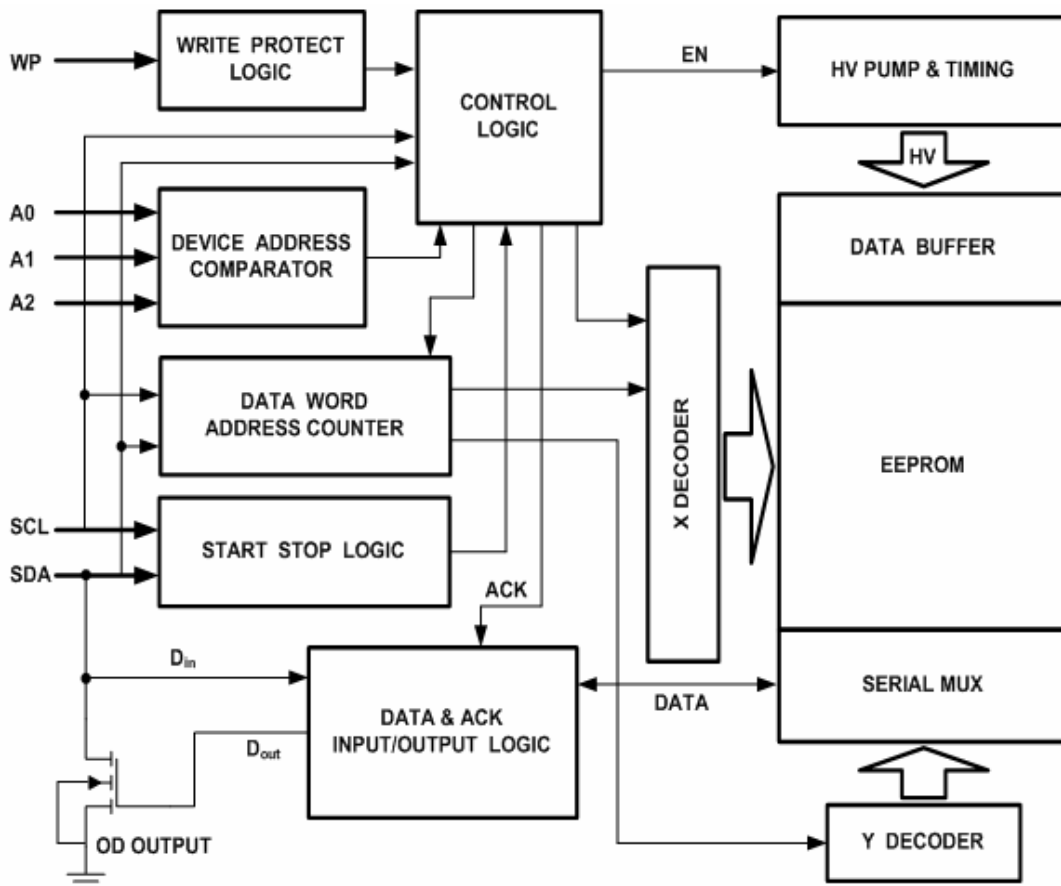
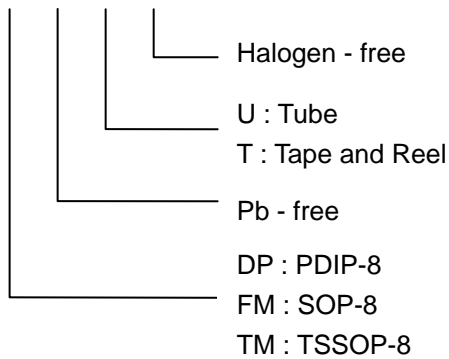

Figure 1

Ordering Information

Selection Guide

ACE24C16A XX + X H



Pin Description

Serial Clock (SCL):

The SCL input is used to positive edge clock data into each EEPROM device and negative edge clock data out of each device.

Serial Data (SDA):

The SDA pin is bi-directional for serial data transfer. This pin is open-drain driven and may be wire-ORed with any number of other open-drain or open-collector devices.

Device/Page Addresses

The ACE24C16A does not use the device address pins, which limits the number of devices on a single bus to one.

Write Protect (WP):

The ACE24C16A has a Write Protect pin that provides hardware data protection. The Write Protect pin allows normal read/write operations when connected to ground (GND). When the Write Protect pin is conceded to Vcc the write protection feature is enabled.

Write Protect Description

WP Pin Status	Part of the Array Protected
WP=V _{CC}	Full (4K) Array
WP=GND	Normal Read / Write Operations

Memory Organization

ACE24C16A, 16K SERIAL EEPROM:

Internally organized with 128 pages of 16 bytes each, the 16K requires an 11-bit data word address for random word addressing.

Pin Capacitance

Applicable over recommended operating range from: $T_A = 25^\circ\text{C}$, $f = 1.0\text{ MHz}$, $V_{CC} = +1.7\text{V}$.

Symbol	Test Condition	Max	Units	Conditions
$C_{I/O}^1$	Input / Output Capacitance (SDA)	8	pF	$V_{I/O} = 0\text{V}$
C_{IN}^1	Input Capacitance (SCL)	6	pF	$V_{IN} = 0\text{V}$

Note: This parameter is characterized and is not 100% tested.

DC Characteristics

Applicable over recommended operating range from: $T_A = -40^\circ\text{C}$ to $+85^\circ\text{C}$, $V_{CC} = +1.7\text{V}$ to $+5.5\text{V}$ (unless otherwise noted).

Symbol	Parameter	Test Condition	Min	Typ	Max	Units
V_{CC}	Supply Voltage		1.7		5.5	V
I_{CC1}	Supply Current	$V_{CC} = 5.5\text{V}$, Read at 400K		0.4	1.0	mA
I_{CC2}	Supply Current	$V_{CC} = 5.5\text{V}$, Write at 400K		2.0	3.0	mA
I_{SB1}	Standby Current	$V_{CC} = 1.7\text{V}$, $V_{IN} = V_{CC}/V_{SS}$			1.0	μA
I_{SB2}	Standby Current	$V_{CC} = 5.5\text{V}$, $V_{IN} = V_{CC}/V_{SS}$			6.0	μA
I_{LI}	Input Leakage Current	$V_{IN} = V_{CC}/V_{SS}$		0.10	3.0	μA
I_{LO}	Output Leakage Current	$V_{OUT} = V_{CC}/V_{SS}$		0.05	3.0	μA
V_{IL}^1	Input Low Level		-0.6		$V_{CC} \times 0.3$	V
V_{IH}^1	Input High Level		$V_{CC} \times 0.7$		$V_{CC} + 0.5$	V
V_{OL}^2	Output Low Level 2	$V_{CC} = 3.0\text{V}$, $I_{OL} = 2.1\text{ mA}$			0.4	V
V_{OL}^1	Output Low Level 1	$V_{CC} = 1.7\text{V}$, $I_{OL} = 0.15\text{ mA}$			0.2	V

Note: 1. V_{IL} min and V_{IH} max are reference only and are not tested.

AC Characteristics

Applicable over recommended operating range from: $T_A = -40^{\circ}\text{C}$ to $+85^{\circ}\text{C}$, $V_{CC} = +1.7\text{V}$ to $+5.5\text{V}$, $CL = 1$ TTL Gate and 100 pF (unless otherwise noted). Test conditions are listed in Note 2.

Symbol	Parameter	1.7-volt		2.5-volt		5.5-volt		Units
		Min	Max	Min	Max	Min	Max	
f_{SCL}	Clock Frequency, SCL		400		1000		1000	kHz
T_{LOW}	Clock Pulse Width Low	1.3		0.4		0.4		μs
T_{HIGH}	Clock Pulse Width High	0.6		0.4		0.4		μs
T_I^1	Noise Suppression Time		100		50		50	ns
T_{AA}	Clock Low to Data Out Valid	0.1	0.9	0.05	0.55	0.05	0.55	μs
T_{BUF}^1	Time the bus must be free before a new transmission can start	1.3		0.5		0.5		μs
$T_{HD,STA}$	Start Hold Time	0.6		0.25		0.25		μs
$T_{SU,STA}$	Start Setup Time	0.6		0.25		0.25		μs
$T_{HD,DAT}$	Data In Hold Time	0		0		0		μs
$T_{SU,DAT}$	Data In Setup Time	100		100		100		ns
T_R	Inputs Rise Time ¹		0.3		0.3		0.3	μs
T_F	Inputs Fall Time ¹		300		100		100	ns
$T_{SU,STO}$	Stop Setup Time	0.6		0.25		0.25		μs
T_{DH}	Data Out Hold Time	50		50		50		ns
T_{WR}	Write Cycle Time		5		5		5	ms
Endurance ⁽¹⁾	3.6V, 25°C, Page Mode	1,000,000						Write Cycles

Notes:1. This parameter is characterized and not 100% tested.

2.AC measurement conditions:

RL (connects to Vcc): $1.3\text{k}\Omega$

Input pulse voltages: $0.3 V_{CC}$ to $0.7 V_{CC}$

Input rise and fall times: $\leq 50\text{ ns}$

Input and output timing reference voltages: $0.5V_{CC}$

Device Operation

Clock and Data Transitions:

The SDA pin is normally pulled high with an external device. Data on the SDA pin may change only during SCL low time periods (refer to Figure 4). Data changes during SCL high periods will indicate a start or stop condition as defined below.

Start Condition:

A high-to-low transition of SDA with SCL high is a start condition which must precede any other command (refer to Figure 5).

Stop Condition:

A low-to-high transition of SDA with SCL high is a stop condition. After a read sequence, the stop command will place the EEPROM in a standby power mode (refer to Figure 5).

Acknowledge:

All addresses and data words are serially transmitted to and from the EEPROM in 8-bit words. The EEPROM sends a zero during the ninth clock cycle to acknowledge that it has received each word. This happens during the ninth clock cycle. Following receipt each word from the EEPROM, the microcontroller should send a zero to EEPROM and continue to output the next data word or send a stop condition to finish the read cycle.

Standby Mode :

The ACE24C16A features a low-power standby mode which is enabled: (a) upon power-up and (b) after the receipt of the stop bit and the completion of any internal operations.

Device Reset :

After an interruption in protocol, power loss or system reset, any two-wire part can be protocol reset by following these steps:

1. Clock up to 9 cycles.
2. Look for SDA high in each cycle while SCL is high and then.
3. Create a start condition as SDA is high

Bus Timing

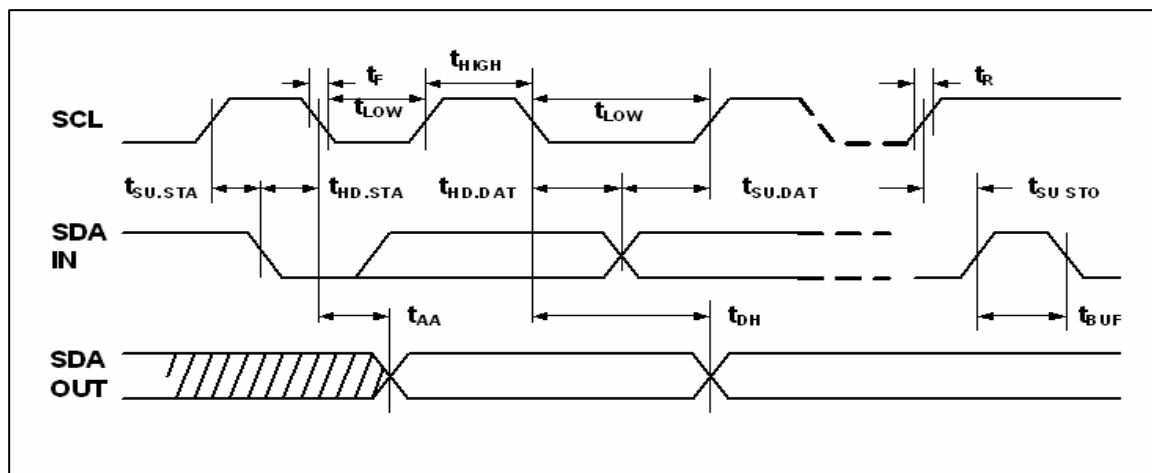

Figure 2 · SCL: Serial Clock, SDA: Serial Data I/O

Write Cycle Timing

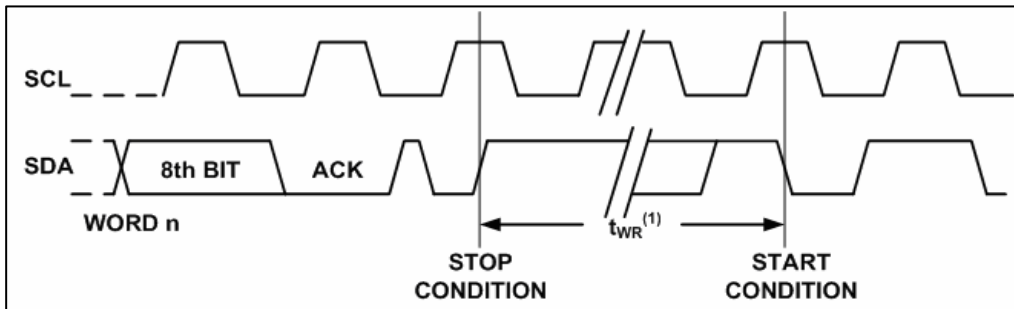

Figure 3. SCL: Serial Clock, SDA: Serial Data I/O

Note: The write cycle time t_{WR} is the time from a valid stop condition of a write sequence to the end of the internal clear/write cycle.

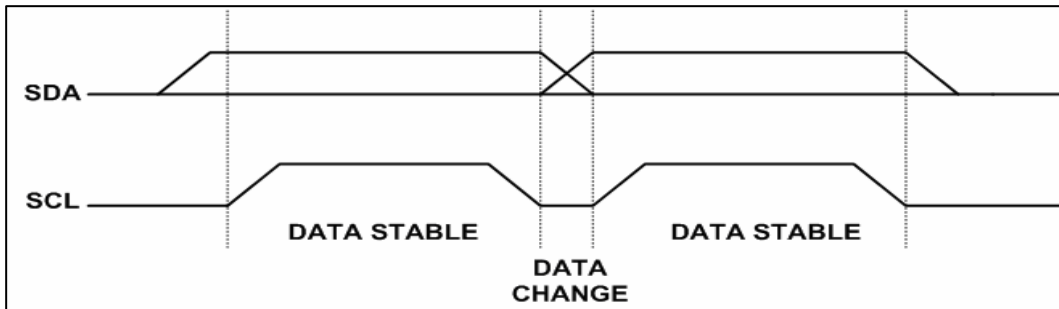

Figure 4 · Data Validity

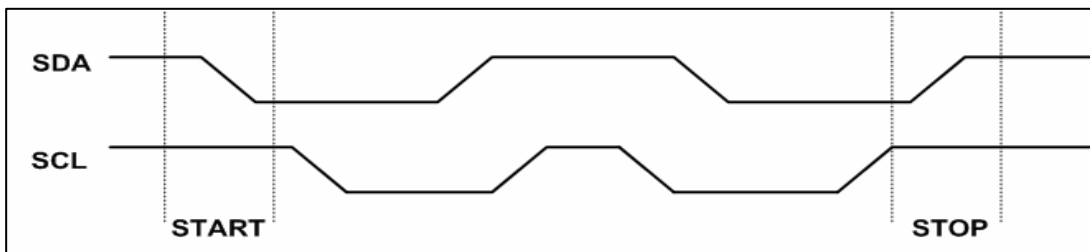

Figure 5 · Start and Stop Definition

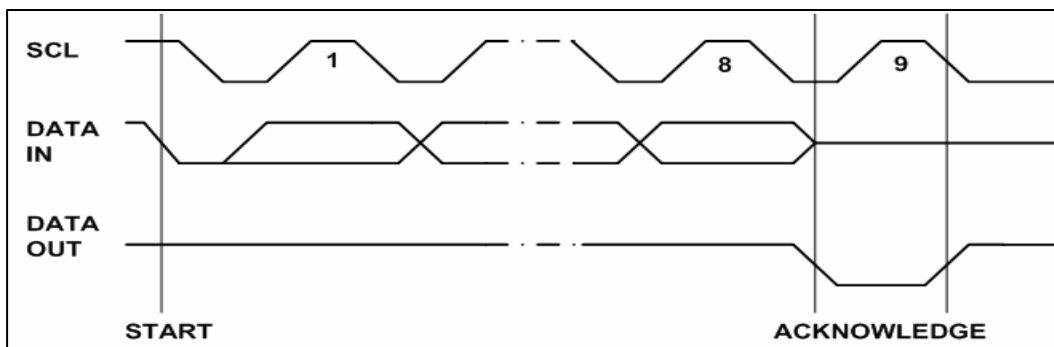

Figure 6 · Output Acknowledge

Device Addressing

The 16K EEPROM devices all require an 8-bit device address word following a start condition to enable the chip for a read or write operation (refer to Figure 7).

The device address word consists of a mandatory one, zero sequence for the first four most significant bits as shown. This is common to all the EEPROM devices.

The next 3 bits used for memory page addressing and are the most significant bits of the data word address which follows.

The eighth bit of the device address is the read/write operation select bit. A read operation is initiated if this bit is high and a write operation is initiated if this bit is low.

Upon a compare of the device address, the EEPROM will output a zero. If a compare is not made, the chip will return to a standby state.

Write Operations

Byte Write

A write operation requires an 8-bit data word address following the device address word and acknowledgment. Upon receipt of this address, the EEPROM will again respond with a zero and then clock in the first 8-bit data word. Following receipt of the 8-bit data word, the EEPROM will output a zero and the addressing device, such as a microcontroller, must terminate the write sequence with a stop condition. At this time the EEPROM enters an internally timed write cycle, t_{WR} , to the nonvolatile memory. All inputs are disabled during this write cycle and the EEPROM will not respond until the write is complete (refer to Figure 8).

Page Write

The 16 devices are capable of 16-byte page writes.

A page write is initiated the same as a byte write, but the microcontroller does not send a stop condition after the first data word is clocked in. Instead, after the EEPROM acknowledges receipt of the first data word, the microcontroller can transmit up to seven more data words. The EEPROM will respond with a zero after each data word received. The microcontroller must terminate the page write sequence with a stop condition (refer to Figure 9).

The data word address lower three bits are internally incremented following the receipt of each data word. The higher data word address bits are not incremented, retaining the memory page row location. When the word address, internally generated, reaches the page boundary, the following byte is placed at the beginning of the same page. If more than eight data words are transmitted to the EEPROM, the data word address will “roll over” and previous data will be overwritten.

Acknowledge Polling

Once the internally timed write cycle has started and the EEPROM inputs are disabled, acknowledge polling can be initiated. This involves sending a start condition followed by the device address word. The read/write bit is representative of the operation desired. Only if the internal write cycle has completed will the EEPROM respond with a zero allowing the read or write sequence to continue.

Read Operations

Read operations are initiated the same way as write operations with the exception that the read/write select bit in the device address word is set to one. There are three read operations: current address read, random address read and sequential read.

Current Address Read

The internal data word address counter maintains the last address accessed during the last read or write operation, incremented by one. This address stays valid between operations as long as the chip power is maintained. The address “roll over” during read is from the last byte of the last memory page to the first byte of the first page. The address “roll over” during write is from the last byte of the current page to the first byte of the same page.

Once the device address with the read/write select bit set to one is clocked in and acknowledged by the EEPROM, the current address data word is serially clocked out. The microcontroller does not respond with an input zero but does generate a following stop condition (refer to Figure 10).

Random Read

A random read requires a “dummy” byte write sequence to load in the data word address. Once the device address word and data word address are clocked in and acknowledged by the EEPROM, the microcontroller must generate another start condition. The microcontroller now initiates a current address read by sending a device address with the read/write select bit high. The EEPROM acknowledges the device address and serially clocks out the data word. The microcontroller does not respond with a zero but does generate a following stop condition (refer to Figure 11).

Sequential Read

Sequential reads are initiated by either a current address read or a random address read. After the microcontroller receives a data word, it responds with an acknowledge. As long as the EEPROM receives an acknowledge, it will continue to increment the data word address and serially clock out sequential data words. When the memory address limit is reached, the data word address will “roll over” and the sequential read will continue. The sequential read operation is terminated when the microcontroller does not respond with a zero but does generate a following stop condition (refer to Figure 12).

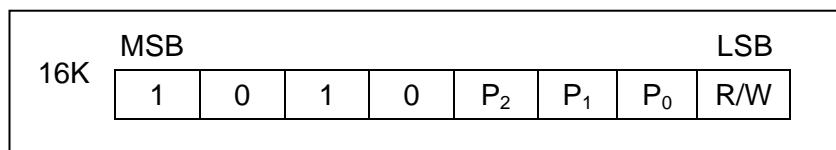

Figure 7 · Device Address

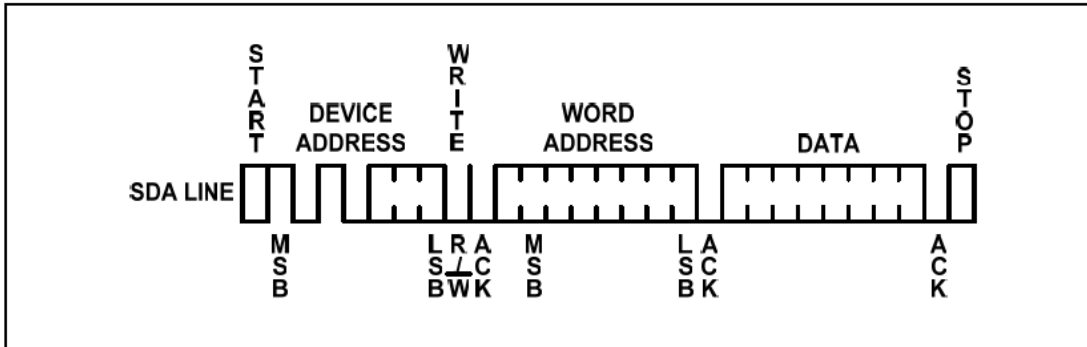

Figure 8 · Byte Write

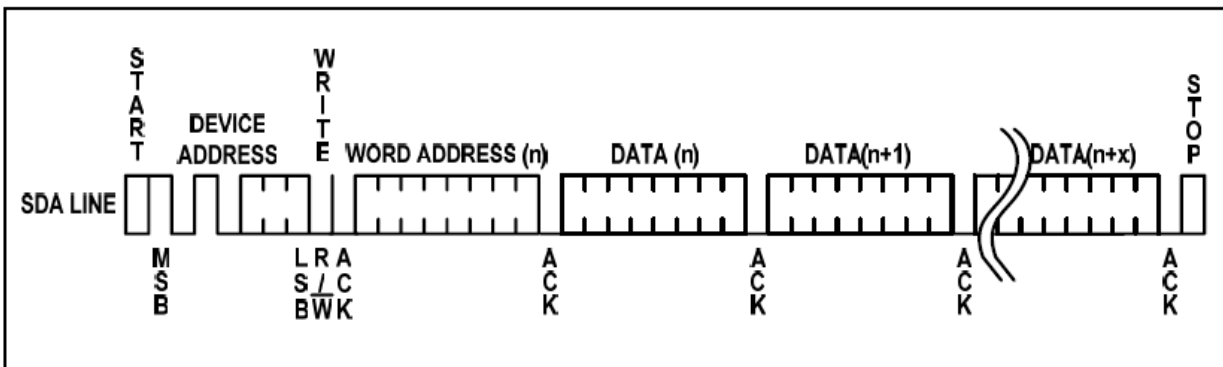

Figure 9 · Page Write

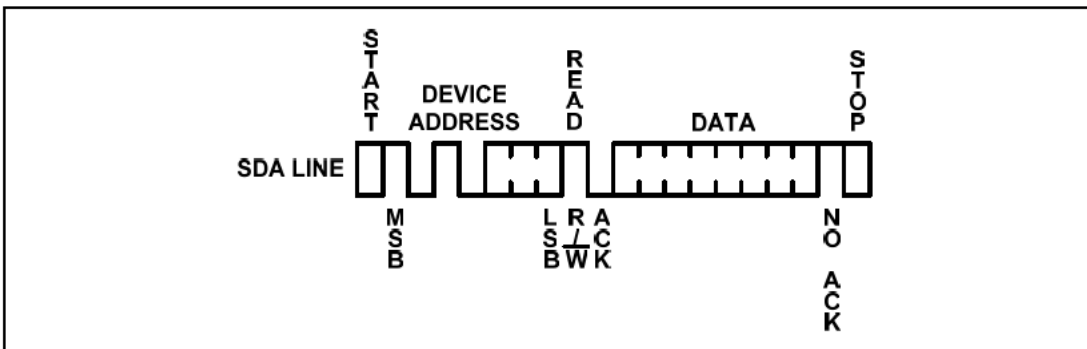

Figure 10 · Current Address Read

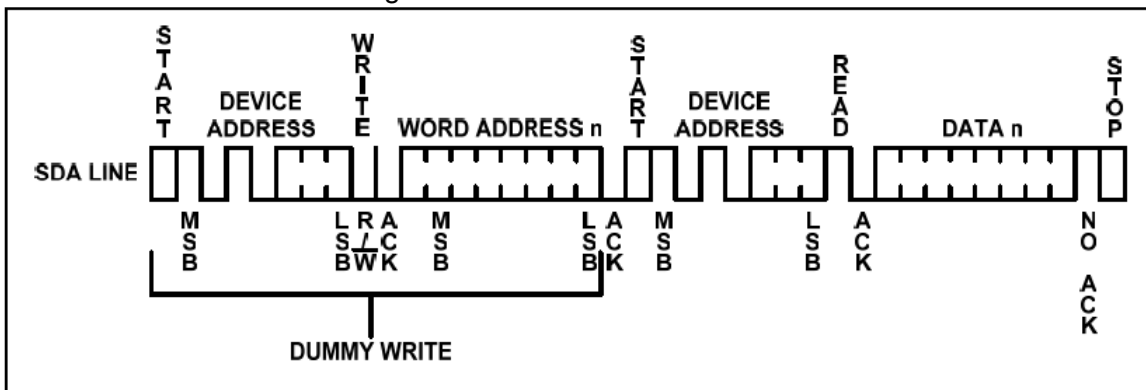

Figure 11 · Random Read

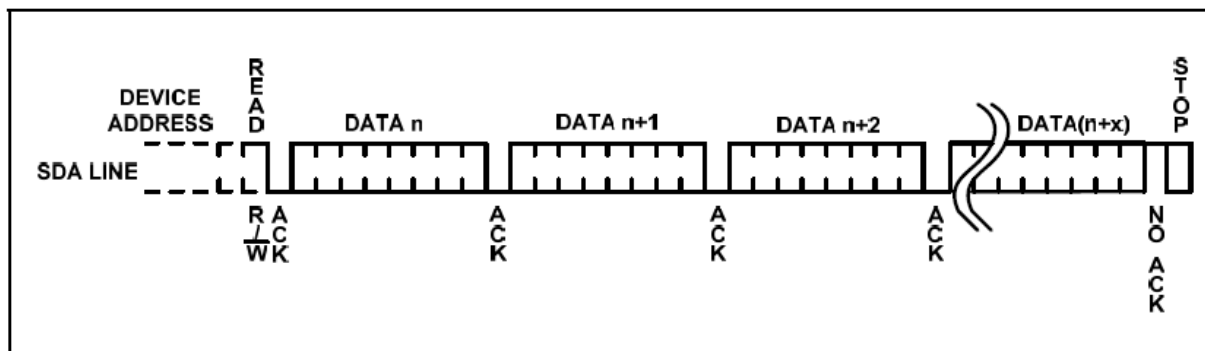
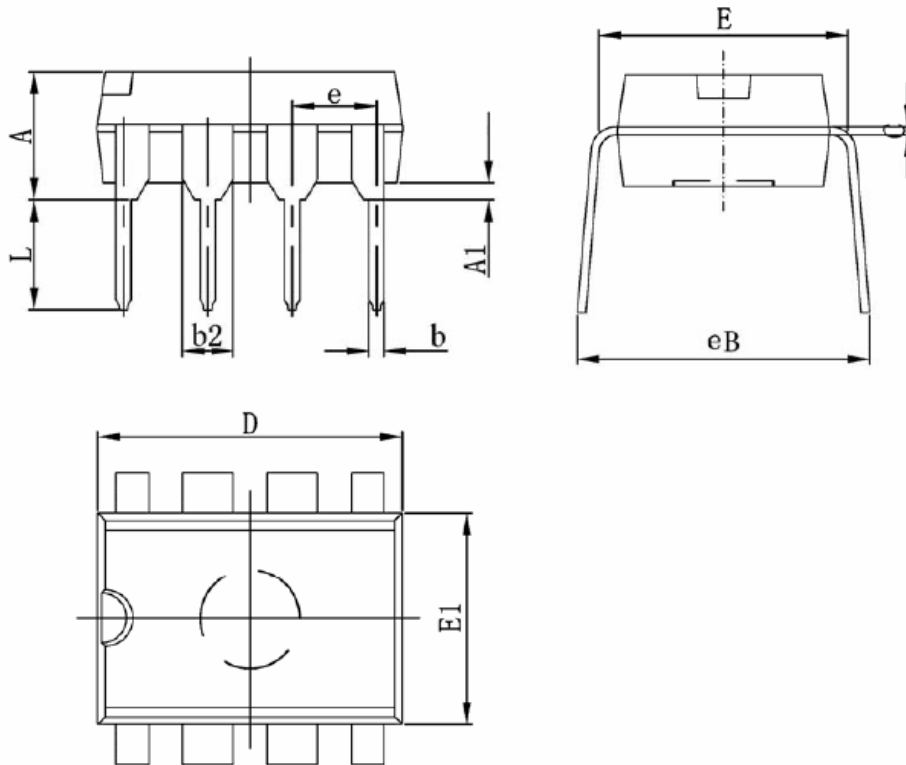

Figure 12 · Sequential Read

Packaging information

PDIP-8



Symbol	MIN	MAX
A	3.710	4.310
A1	0.510	
b	0.380	0.570
b2	1.524(BSC)	
C	0.204	0.360
D	9.000	9.400
E1	6.200	6.600
E	7.320	7.920
e	2.540(BSC)	
L	3.000	3.600
eB	8.400	9.000

NOTE:
1. Dimensions are in Millimeters.

SOP-8

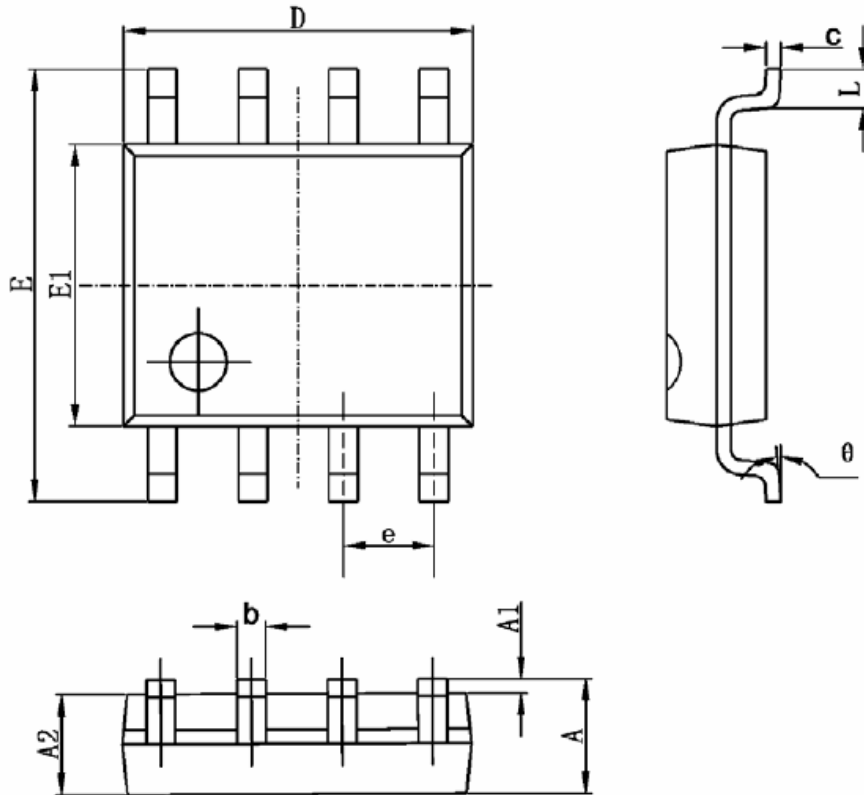

Symbol	MIN	MAX
A	1.350	1.750
A1	0.100	0.250
A2	1.350	1.550
b	0.330	0.510
c	0.170	0.250
D	4.700	5.100
E1	3.800	4.000
E	5.800	6.200
e	1.270(BSC)	
L	0.400	1.270
θ	0°	8°

NOTE:

1. Dimensions are in Millimeters.

TSSOP-8

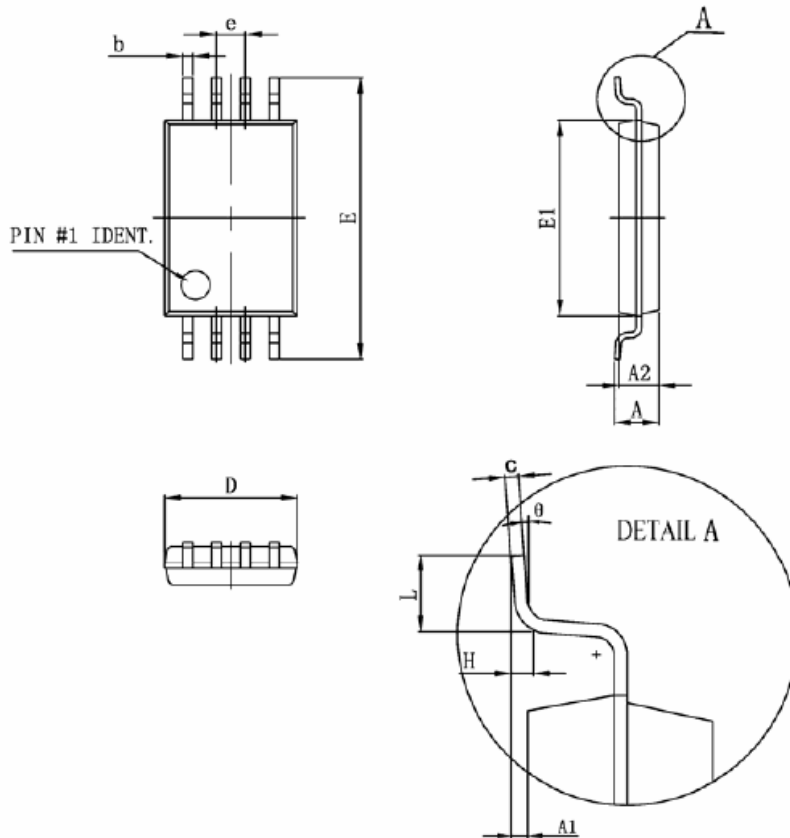

Symbol	MIN	MAX
D	2.900	3.100
E1	4.300	4.500
b	0.190	0.300
c	0.090	0.200
E	6.250	6.550
A		1.100
A2	0.800	1.000
A1	0.050	0.150
e	0.650 (BSC)	
L	0.500	0.700
H	0.250 (TYP)	
θ	1°	7°

NOTE:

1. Dimensions are in Millimeters.

Notes

ACE does not assume any responsibility for use as critical components in life support devices or systems without the express written approval of the president and general counsel of ACE Electronics Co., LTD. As sued herein:

1. Life support devices or systems are devices or systems which, (a) are intended for surgical implant into the body, or (b) support or sustain life, and whose failure to perform when properly used in accordance with instructions for use provided in the labeling, can be reasonably expected to result in a significant injury to the user.
2. A critical component is any component of a life support device or system whose failure to perform can be reasonably expected to cause the failure of the life support device or system, or to affect its safety or effectiveness.

ACE Technology Co., LTD.
<http://www.ace-ele.com/>