

Description

ACE520 dual, low-noise, low-dropout regulator delivers at least 300mA of continuous output current. The output voltage for each regulator is set independently by trimming. Output voltages are selectable in 100mV steps within a range of 1.2V to 3.5V. Typical output noise is 47uV_{rms}, and PSRR is 73dB at 100Hz. The ACE520 includes two independent logic-controlled shutdown inputs and allows the output of each regulator to be turned of independently.

The ACE520 includes high accuracy voltage reference, error amplifier, current limit circuit and output driver module.

The ACE520 has excellent load and line transient response and good temperature characteristics, which can assure the stability of chip and power system. And it uses trimming technique to guarantee output voltage accuracy within $\pm 2\%$.

Features

- Two low dropout voltage regulators
- 300mA output current for each LDO
- 25uA operating supply current per LDO
- Low 47uV_{RMS} output noise
- Standby Mode: 0.1uA
- Low 160mV dropout at 300mA load
- 73dB PSRR at 100Hz
- Excellent Line regulation: 0.05%/V
- Independent Shutdown controls
- 1.2V to 3.5V Factory-Preset Output
- Output Current Limit
- Highly Accurate: $\pm 2\%$ ($\pm 1\%$ customized)

Application

- Cellular phones
- Cordless phones and radio communication equipment
- Battery Powered equipment
- Notebook and hand-ole equipment
- Wireless LAN
- GPS receivers

Absolute Maximum Ratings

Parameter	Symbol	Max	Unit
Input voltage	V _{IN}	8	V
Power Dissipation SOT-23-6		250	mW
Junction temperature	T _J	125	°C
Storage temperature	T _S	- 45 to 150	°C
Ambient Temperature	T _A	-40 to 85	°C

Note: Exceed these limits to damage to the device. Exposure to absolute maximum rating conditions may affect device reliability.

Packaging Type

SOT-23-6

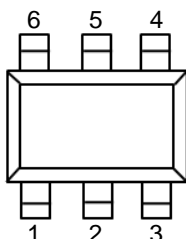

Pin	SOT-23-6(D)	SOT-23-6(E)	Function
V _{out1}	6	6	Output 1 pin
V _{dd}	2	5	Input pin
V _{out2}	4	1	Output 2 pin
CE2	3	3	Chip Enable pin2
GND	5	2	Ground pin
CE1	1	4	Chip Enable pin1

Ordering information

Selection Guide

ACE520 X XXX + H

Halogen - free

Pb - free

DGM : SOT-23-6D

EGM : SOT-23-6E

Output Voltage :

B:1.5V(Output1),2.8V(Output2)

C:1.5V(Output1),3.0V(Output2)

D:1.5V(Output1),3.3V(Output2)

E:1.5V(Output1),4.0V(Output2)

G:1.8V(Output1),2.5V(Output2)

H:1.8V(Output1),2.8V(Output2)

I: 1.8V(Output1),3.0V(Output2)

J:1.8V(Output1),3.3V(Output2)

M:2.8V(Output1),1.8V(Output2)

O:2.8V(Output1),2.8V(Output2)

P:2.8V(Output1),3.0V(Output2)

Q:3.0V(Output1),2.5V(Output2)

R:3.0V(Output1),3.0V(Output2)

S:3.0V(Output1),3.3V(Output2)

T:3.3V(Output1),1.8V(Output2)

Z:3.3V(Output1),3.3V(Output2)

a:1.2V(Output1),2.5V(Output2)

b:2.8V(Output1),1.2V(Output2)

c:2.8V(Output1),1.3V(Output2)

d:2.5V(Output1),2.8V(Output2)

e:2.5V(Output1),3.3V(Output2)

f:2.8V(Output1),3.3V(Output2)

g: 1.3V(Output1),2.8V(Output2)

Block Diagram

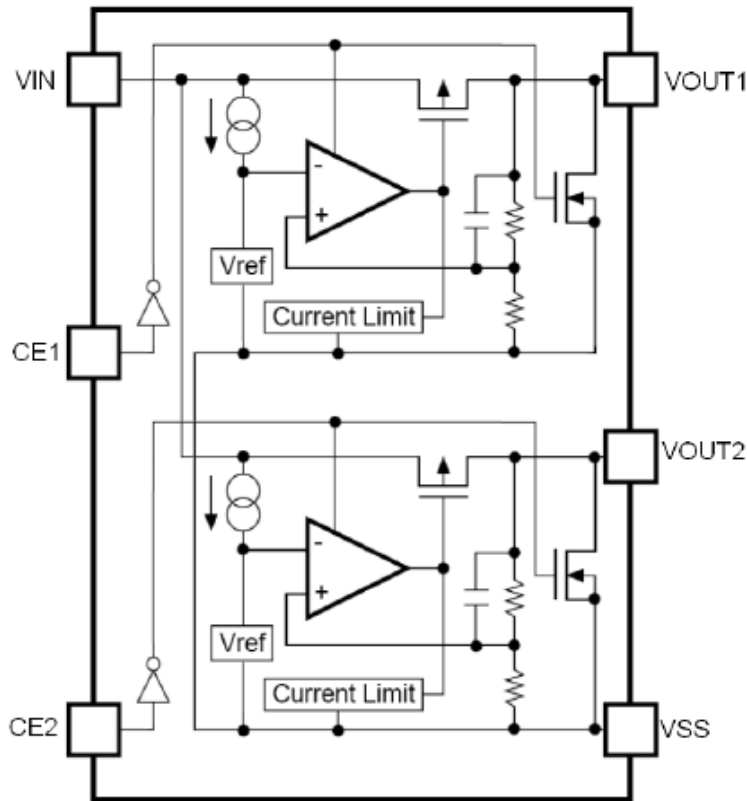

Explanation

ACE520 series are highly accurate, dual, low noise, CMOS low dropout voltage regulators. The output voltage for each regulator is set independently by trimming. Voltages are selectable in 100mV steps within a range of 1.2V to 3.5V. It also can be customized on command.

ACE520 includes high accuracy voltage reference, error amplifier, current limit circuit and output driver module.

ACE520 has excellent load and line transient response and good temperature characteristics, which can assure the stability of chip and power system. And it uses trimming technique to guarantee output voltage accuracy within $\pm 2\%$.

Recommended Work Conditions

Item	Min	Max	Unit
Input Voltage Range		6	V
Ambient Temperature	-40	85	°C

Electrical Characteristics

(Test Conditions: C1=1uF, Cout=3.3uF, TA=25°C, unless otherwise specified.)

ACE520, For arbitrary output voltage

Parameter	Symbol	Conditions	Min	Typ	Max	Units
Input Voltage	V _{IN}				6	V
Output Voltage	V _{OUT}	V _{in} =Set V _{out} +1V 1mA ≤ I _{out} ≤ 30mA	V _{out} x0.98		V _{out} x1.02	V
Maximum Output Current	I _{OUT} (Max.)	V _{in} -V _{out} =1V	300			mA
Dropout Voltage, V _{out} ≥ 2.8V	V _{drop}	I _{out} =100mA		50	80	mV
		I _{out} =300mA		160	220	
Line Regulation	$\frac{\Delta V_{OUT}}{\Delta V_{IN}} \cdot V_{OUT}$	I _{out} =40mA 2.8V ≤ V _{in} ≤ 6V		0.05	0.2	%/V
Load Regulation	$\frac{\Delta V_{OUT}}{\Delta I_{OUT}}$	V _{in} =Set V _{out} +1V 1mA ≤ I _{out} ≤ 300mA		30	50	mA
Supply Current	I _{ss}	V _{in} =Set V _{out} +1V		50	100	uA
Supply Current (Srandby)	I _{standby}	V _{in} =Set V _{out} +1V V _{ce} =Gnd		0.1	1.0	uA
Output Voltage Temperature Coefficiency	$\frac{\Delta V_{OUT}}{\Delta T} \cdot V_{OUT}$	I _{out} =30mA		±100		ppm/°C
Ripple Rejection	PSRR	F=100Hz Ripple=0.5Vp-p V _{in} =Set V _{out} +1V		70		dB
Short Current Limit	L _{lim}	V _{out} =0V		500		mA
CE Input Voltage "H"	V _{ceh}		1.5		V _{in}	V
CE Input Voltage "L"	V _{cel}		0		0.25	V
Output Noise	en	BW=10Hz~100kHz		47		uVrms

Typical Application Circuit

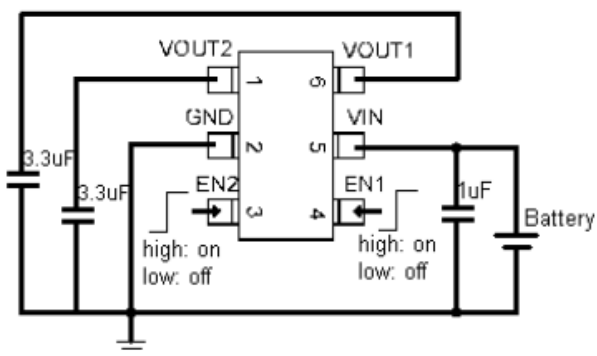

Application hints:

Note: Input capacitor(C_{in}=1uF) and Output capacitor(C_{out}=1uF/3.3uF) are recommended in all application circuit.

Electrical Characteristics

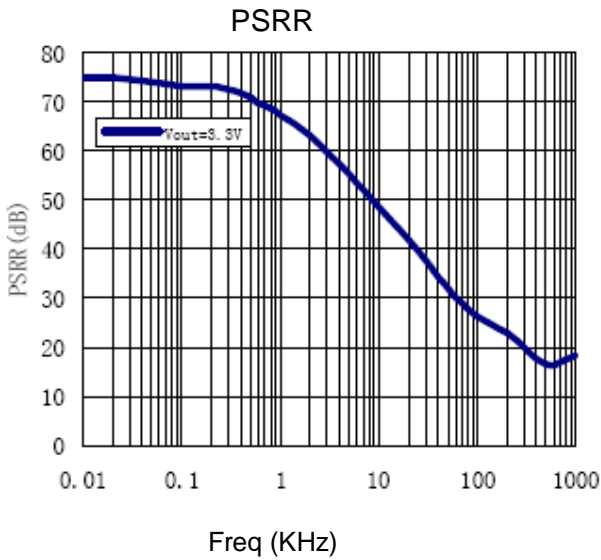

Typical Performance Characteristics

Output Voltage vs. Output Current
(with output short protection)

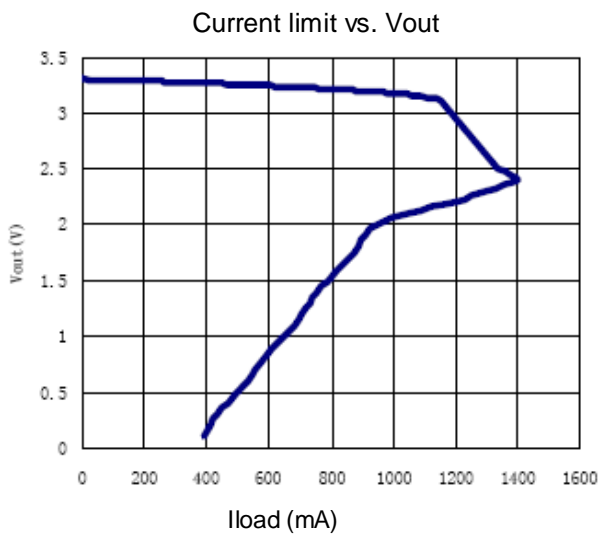

Output Voltage vs. Input Voltage

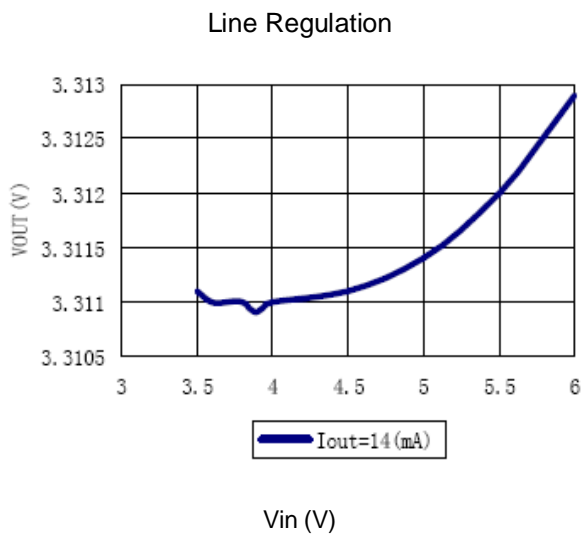

Dropout Voltage vs. Output Current

Ripple rejection vs. Frequency

Dropout & Iout

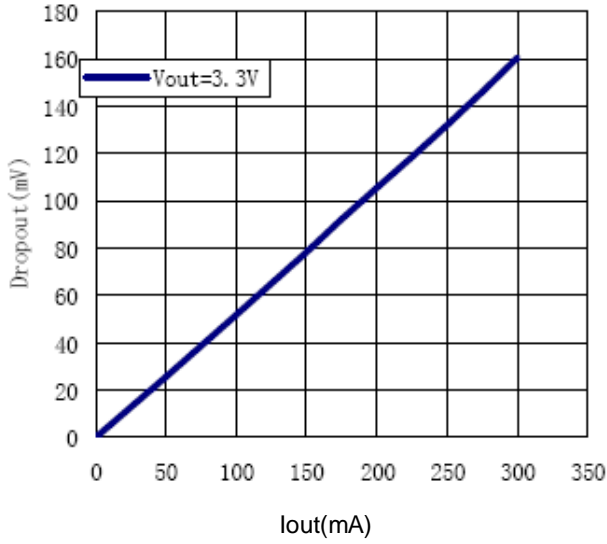

PSRR

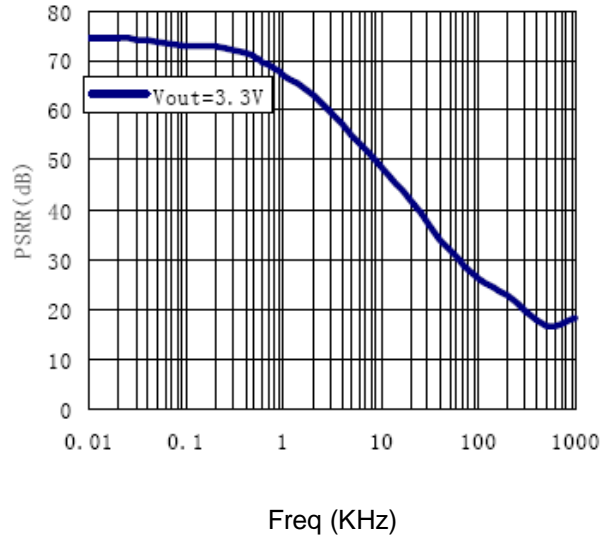

Line transient response
Cin=Cout=1uF Iout=25mA Vout=3.3V

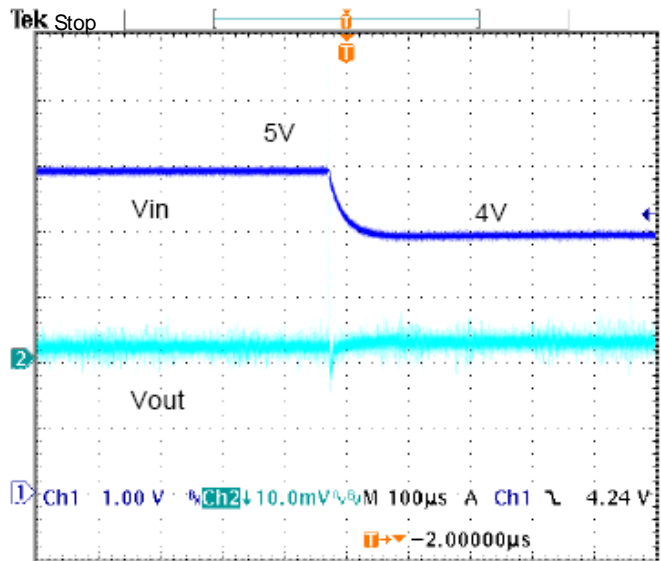
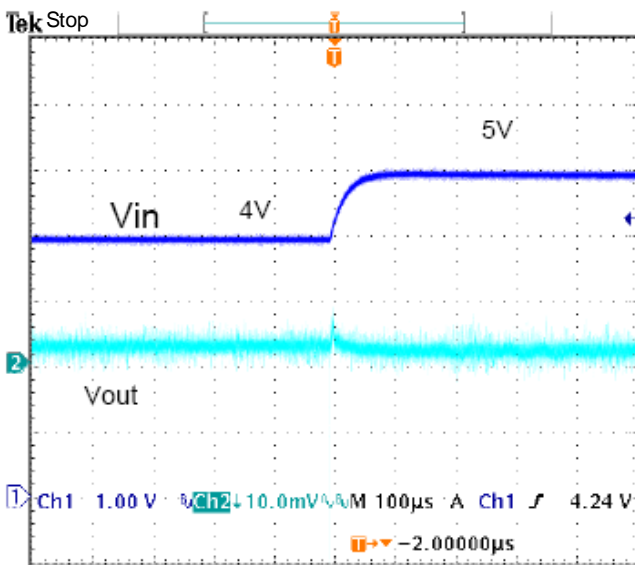

Load transient response

$C_{in}=C_{out}=1\mu F$ $V_{out}=4.5V$ $V_{out}=3.3V$

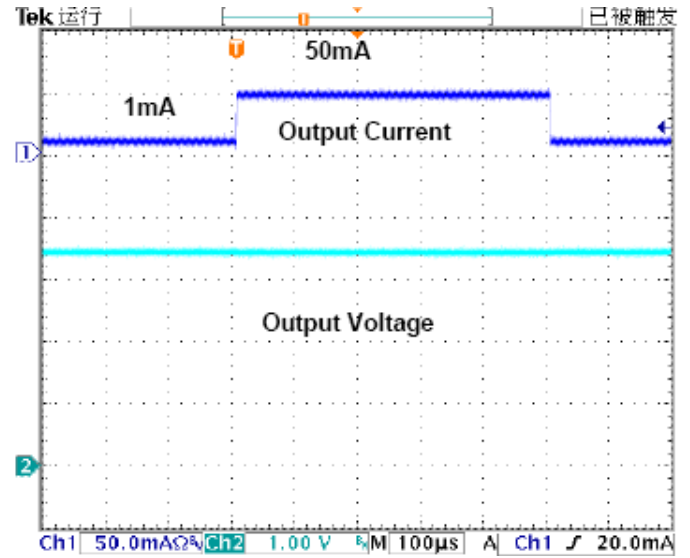
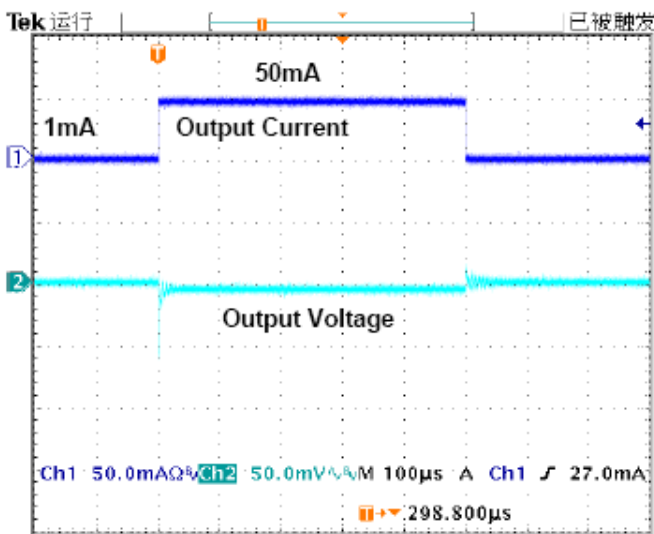

Start up from EN

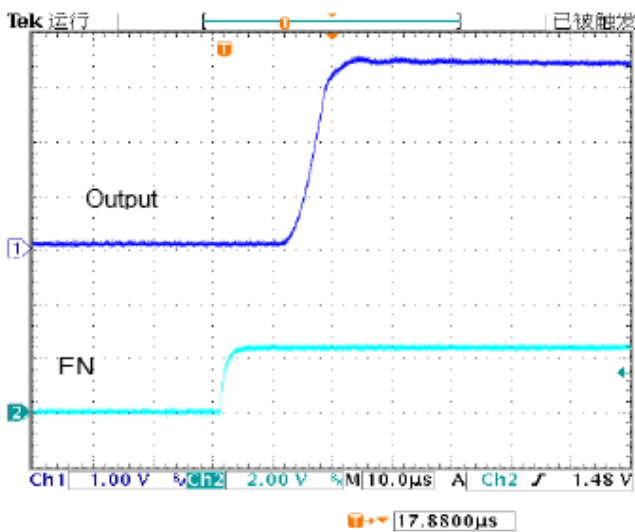

Shut down from EN

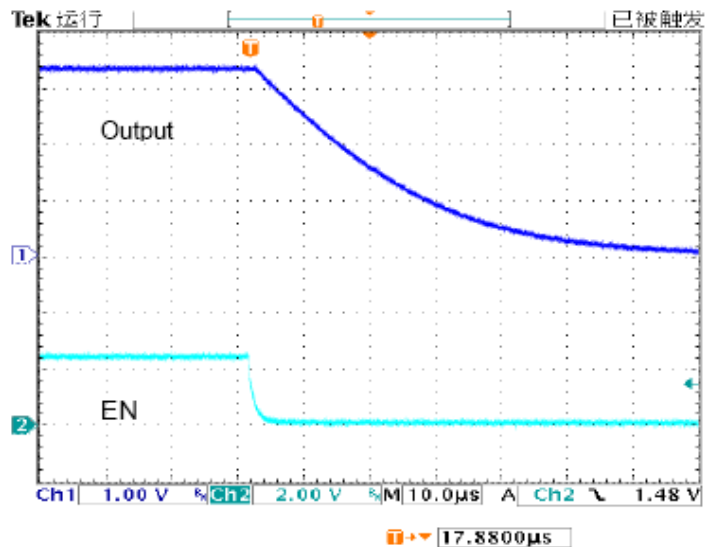

Packing Information

SOT-23-6

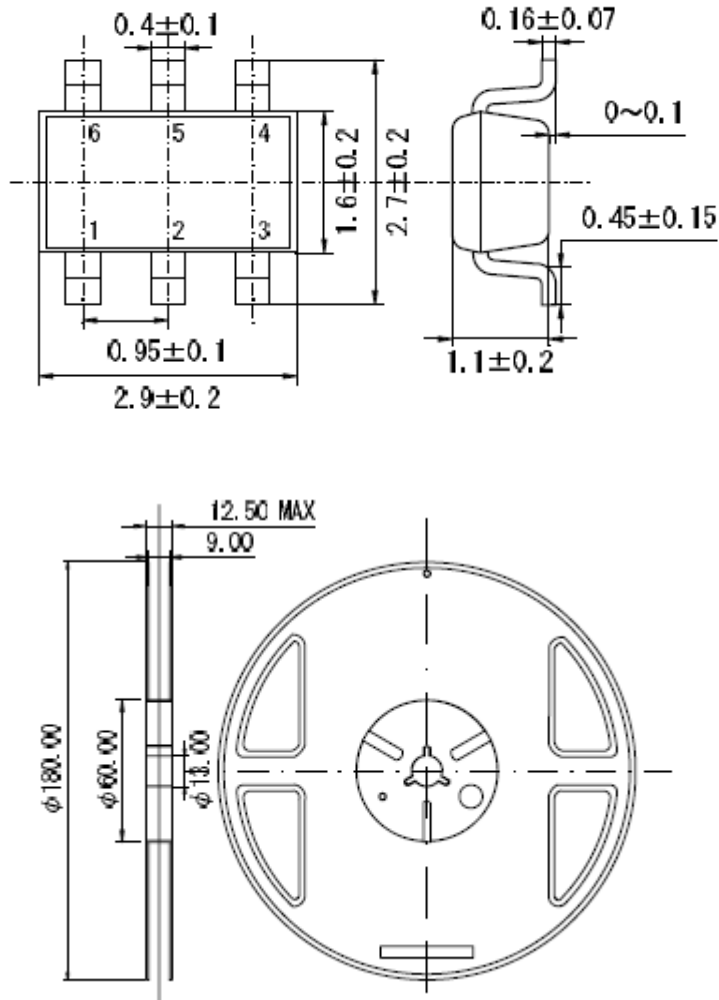

Notes

ACE does not assume any responsibility for use as critical components in life support devices or systems without the express written approval of the president and general counsel of ACE Electronics Co., LTD. As sued herein:

1. Life support devices or systems are devices or systems which, (a) are intended for surgical implant into the body, or (b) support or sustain life, and whose failure to perform when properly used in accordance with instructions for use provided in the labeling, can be reasonably expected to result in a significant injury to the user.
2. A critical component is any component of a life support device or system whose failure to perform can be reasonably expected to cause the failure of the life support device or system, or to affect its safety or effectiveness.