

Description

The ACE605 series are high performance linear voltage regulators that provide ultra low-dropout voltage, high output current in lowest output voltage. It operates from an input of 1.4V to 5.5V and provides output current up to 2A thus is suitable to drive digital circuits requiring low voltage at high currents.

The ACE605 has superior regulation over variations in line and load. Also it provides fast respond to step changes in load. Other features include over-current and overtemperature protection. The adjustable version has enable pin to reduce power consumption in shutdown mode.

The devices are available ADJ output, and via external R adjust output voltage from 0.6V to $V_{in}-0.3V$, 0.6V is the reference voltage. The BM9165 have enable function, that is good for portable system for main chip on and off. In order to have lower dropout and bigger current output V_{en} should 0.8~1.0V higher than V_{in} , but can work if same. Power pad sop8 can output over 2A and 1.6A without the pad.

Features

- 300mV Dropout @ 2A (1.2V output)
- <300µA Low Ground Pin Current
- Excellent Line and Load Regulation
- 0.1µA Quiescent Current in Shutdown Mode
- Guaranteed >2A Output Current
- Fixed Output Voltages: 1.05V, 1.2V, 1.8V, 2.5V
- Adjustable Output Voltage from 0.6V to 4.5V
- Over-Temperature/Over-Current Protection

Application

- Card reader and Battery-Powered Equipment
- Mother Board/Graphic Card
- LCD-TV, NET BOOK, USB Net card
- NET-BOOK, pin-pin with RT9025, RT9018

Packaging Type

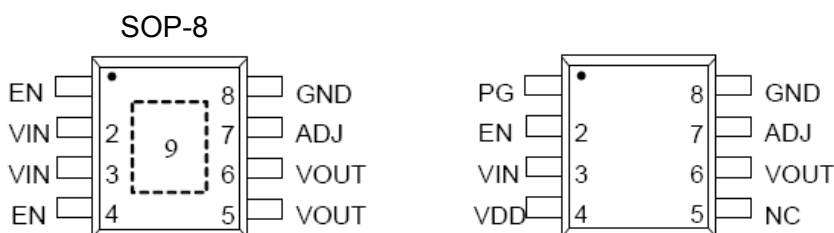

Pin	Function
EN	Chip ENABLE Control Input. Logic enable On logic 3.3V/5V. Note that the device will be in the unstable state if the pin is not connected
VIN	Supply Input
GND	Common Ground
VOUT	Regulator Output
ADJ	The output voltage is set by the internal feedback resistors when this pin grounded. If external feedback resistors are applied, the output voltage will be: $V_{out}=0.6*(1+R1/R2)$ Volts

Pin Description

Selection Guide

ACE605 X X XX + H

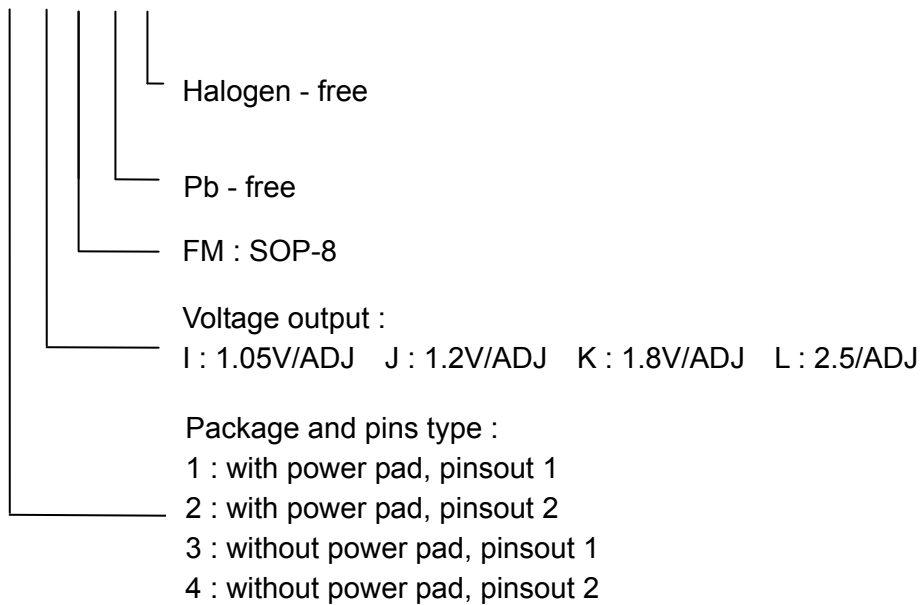

Application of ACE605

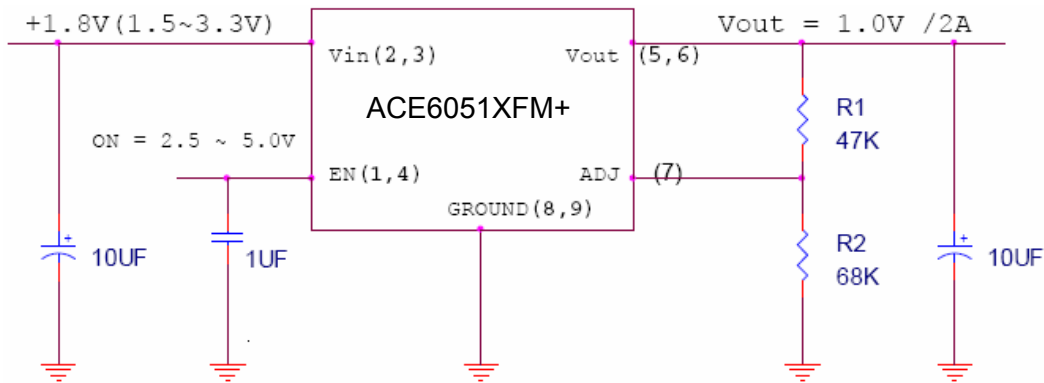

$$V_{out} = 0.6 * (1 + R1/R2)$$

Above is adjustable output and below is the fixed 1.8V voltage output circuit

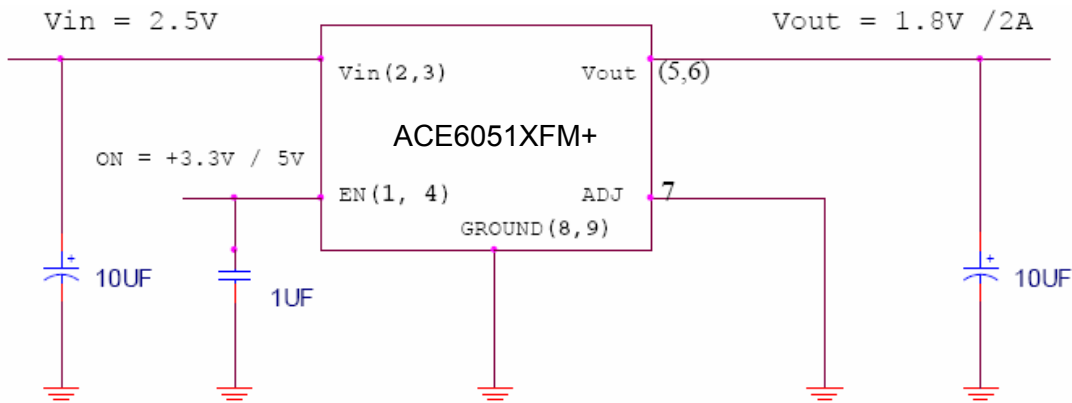

Notes:

In order to get better dropout and larger output current, keep V_{en} higher +0.8V or more than V_{in} , which also result in better output ripple.

1. in order to have a lower ripple output voltage, pls. add a small capacitor from enable pin to ground
2. pull up enable pin to 3.3V or 5V, the voltage, the better, is higher than v_{in} .
3. the fixed output voltage version is also adjustable via two external resistors, adjust from 0.6V.
4. if enable voltage is same as V_{in} , the dropout voltage is 1V, if higher than $V_{in} + 0.8V$, the dropout voltage can be less than 0.3V

Functional Block Diagram

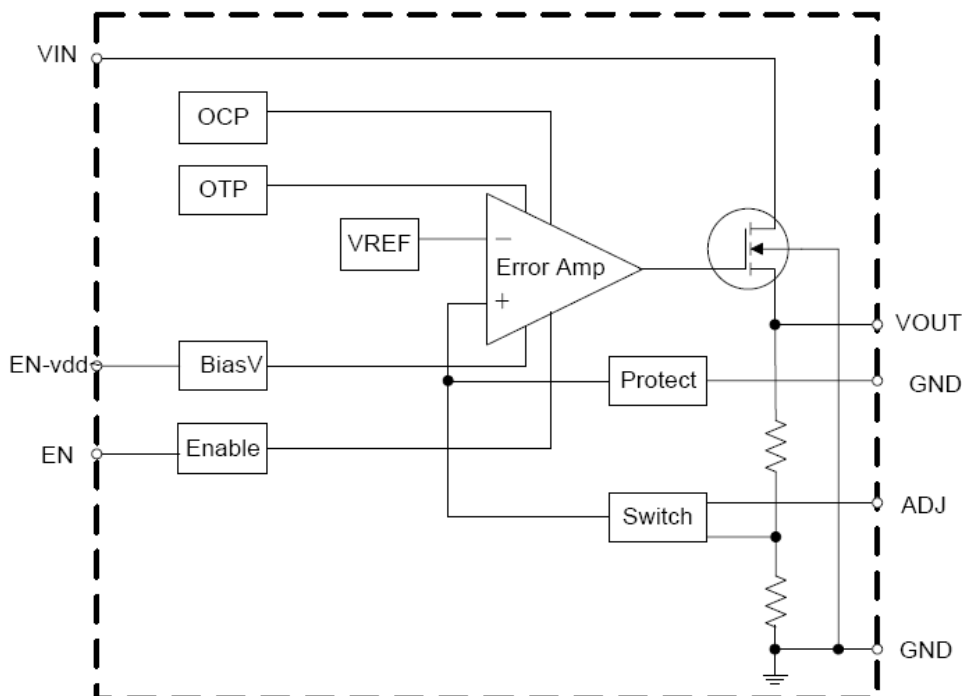

Absolute Maximum Ratings

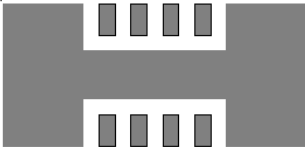
Parameter	Symbol	Max	Unit
Supply Input Voltage	V_{IN}	6	V
Package Thermal Resistance (75°C/W without power pad)	θ_{JA}	50	°C/W
Power Dissipation PD@ $T_A=25^\circ\text{C}$  if PCB Copper Area=70mm ² , SOP-8 with power pad $P\text{-max}=(125-25)/50=2\text{W}$ (1.3W without power pad)			
Lead Temperature (Soldering, 10sec.)		260	°C
Junction Temperature		150	°C
Storage Temperature Range		-65~150	°C
ESD Susceptibility HBM (Human Bode Mode) MM(Machine Mode)		2KV 200V	V

Recommended Work Conditions

Item	Min	Recommended	Max	Unit
Supply Input Voltage	1.3		5.5	V
Junction Temperature Range	-40		+125	°C

Electrical Characteristics

($V_{in}=V_{out}+0.7\text{V}$, $C_{in}=C_{out}=10\mu\text{F}$ (Ceramic), $T_A=25^\circ\text{C}$ unless otherwise specified)

Parameter	Symbol	Test Conditions	Min	Typ	Max	Units
Output Voltage Accuracy (Fixed Output Voltage)	ΔV_{OUT}	$I_{OUT}=10\text{mA}$	-2	0	+2	%
Output Voltage Range (Adjustable)	V_{OUT_ADJ}		0.6		4.5	V
Quiescent Current (Note 6)	I_Q	$I_{OUT}=0\text{mA}$, Enable		250		μA
Standby Current	I_{STBY}	$V_{IN}=5.5\text{V}$, Shutdown		0.1	1	μA
Current Limit	I_{LIM}		2.5	3	3.5	A
Dropout Voltage (Note 4)		$I_{OUT}=0.5\text{A}$		100		mV
		$I_{OUT}=1.0\text{A}$		180		
		$I_{OUT}=2.0\text{A}$		300		
Line Regulation	ΔV_{LINE}	$V_{OUT}+0.5\text{V}<V_{IN}<5.5\text{V}$		0.035	0.18	%/V

				$I_{OUT}=10mA$		
Load Regulation (Note 5) (Fixed Output Voltage)		ΔV_{LOAD}	$1mA < I_{OUT} < 2A$	15	35	mV
Thermal Shutdown Temperature		T_{SD}		150		$^{\circ}C$
Thermal Shutdown Hysteresis		ΔT_{SD}		20		$^{\circ}C$
En Threshold	Logic-Low Voltage	V_{IL}	$V_{IN}=5.5V$		0.4	V
	Logic-High Voltage	V_{IH}	$V_{IN}=5.5V$	1.5		
Enable Pin Current		I_{EN}	$V_{IN}=5.5V$, Enable	0.1	1	μA
ADJ						
Reference Voltage Tolerance		V_{REF}		0.587	0.6	0.613
Adjust Pin Current		I_{ADJ}	$V_{ADJ}=V_{REF}$		10	100
Adjust Pin Threshold		$V_{TH(ADJ)}$		0.05	0.15	0.2

Note:

1. Stresses listed as the above "Absolute Maximum Ratings" may cause permanent damage to the device. These are for stress ratings. Functional operation of the device at these or any other conditions beyond those indicated in the operational sections of the specifications is not implied. Exposure to absolute maximum rating conditions for extended periods may remain possibility to affect device reliability.
2. Devices are ESD sensitive. Handling precaution recommended.
3. The device is not guaranteed to function outside its operating conditions.
4. The dropout voltage is defined as $V_{IN} - V_{OUT}$, which is measured when V_{OUT} is $V_{OUT(NORMAL)} - 100mV$.
5. Regulation is measured at constant junction temperature by using a 20ms current pulse. Devices are tested for load regulation in the load range from 10mA to 2A.
6. Quiescent, or ground current, is the difference between input and output currents. It is defined by $I_Q = I_{IN} - I_{OUT}$ under no load condition ($I_{OUT} = 0mA$). The total current drawn from the supply is the sum of the load current plus the ground pin current.
7. Try to layout the pads larger to get better heat-sink, result in larger current output.

Application of ACE6052XFM+ and ACE6054XFM+

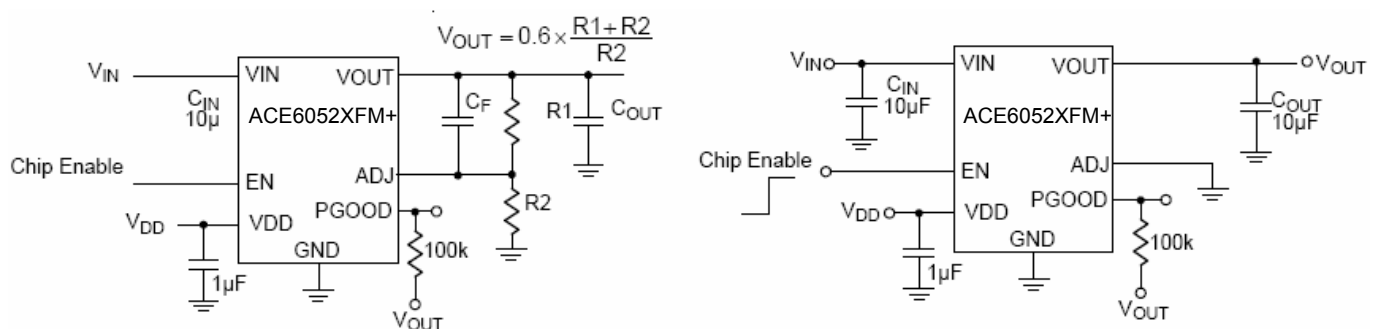

Packing Information

SOP-8

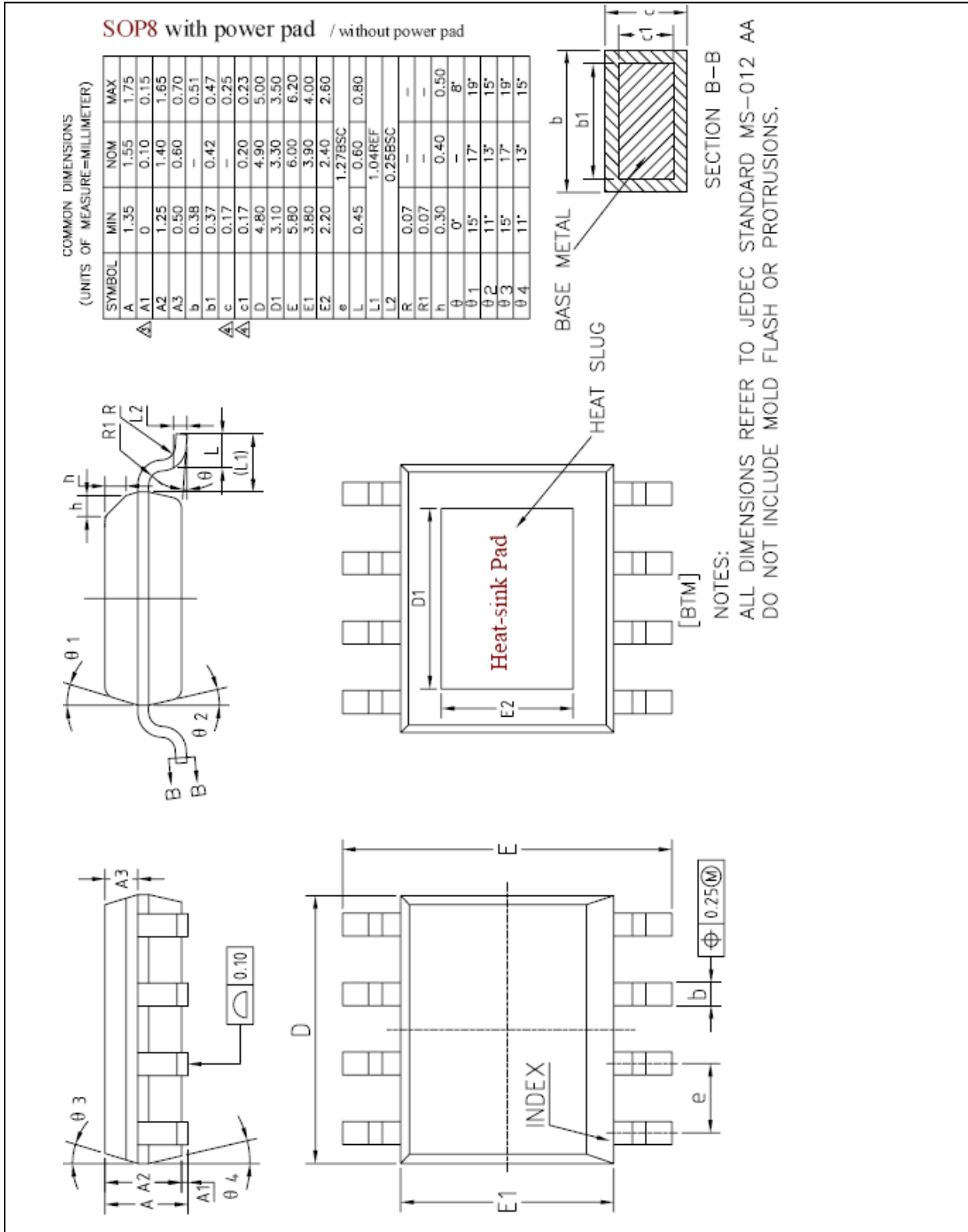

Notes

ACE does not assume any responsibility for use as critical components in life support devices or systems without the express written approval of the president and general counsel of ACE Electronics Co., LTD. As sued herein:

1. Life support devices or systems are devices or systems which, (a) are intended for surgical implant into the body, or (b) support or sustain life, and whose failure to perform when properly used in accordance with instructions for use provided in the labeling, can be reasonably expected to result in a significant injury to the user.
2. A critical component is any component of a life support device or system whose failure to perform can be reasonably expected to cause the failure of the life support device or system, or to affect its safety or effectiveness.

ACE Technology Co., LTD.
<http://www.ace-ele.com/>