

Description

The ACE624 is a dual channel electronic volume controlled with 2-wire serial data. The built-in reference circuit can compose of an electronic volume with less external parts.

Features

- Built-in reference circuit
- Control with serial data Volume 0 to -83dB (1dB/step), $-\infty$ (Independent control is allowed in each channel)
- Low noise and low distortion $V_{NO}=5\mu V_{rms}$ (ATT= $-\infty$, JIS-A) THD=0.01% Typ. ($V_0=0.5V_{rms}$, DIN-AUDIO)

Recommended Operating Conditions

Supply voltage range..... $V_{cc} = 4.5$ to $5.5V$

Rated supply voltage..... $V_{cc} = 5V$

Absolute Maximum Ratings

Symbol	Parameter	Ratings	Unit
V_{cc}	Supply voltage	6.0	V
P_d	Power dissipation	625(p),440(FP)	mW
T_{opr}	Operating temperature	-20 to +75	$^{\circ}C$
T_{stg}	Storage temperature	-55 to +125	$^{\circ}C$

Packaging Type

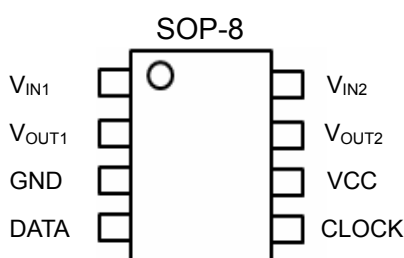

Pin No	Symbol	Function
1	V_{IN1}	1-ch input pin
2	V_{OUT1}	1-ch output pin
3	GND	Ground pin
4	DATA	Control data input pin. Inputs data in synchronization with clock
5	CLOCK	Clock input pin for transferring serial data
6	VCC	Power supply pin. Stabilize the pin with decoupling capacitor
7	V_{OUT2}	2-ch output pin
8	V_{IN2}	1-ch input pin

Ordering information

Selection Guide

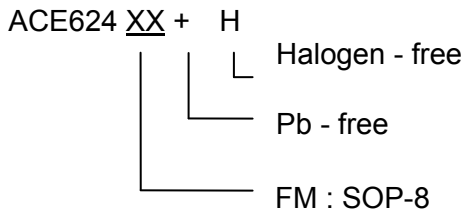

Block Diagram

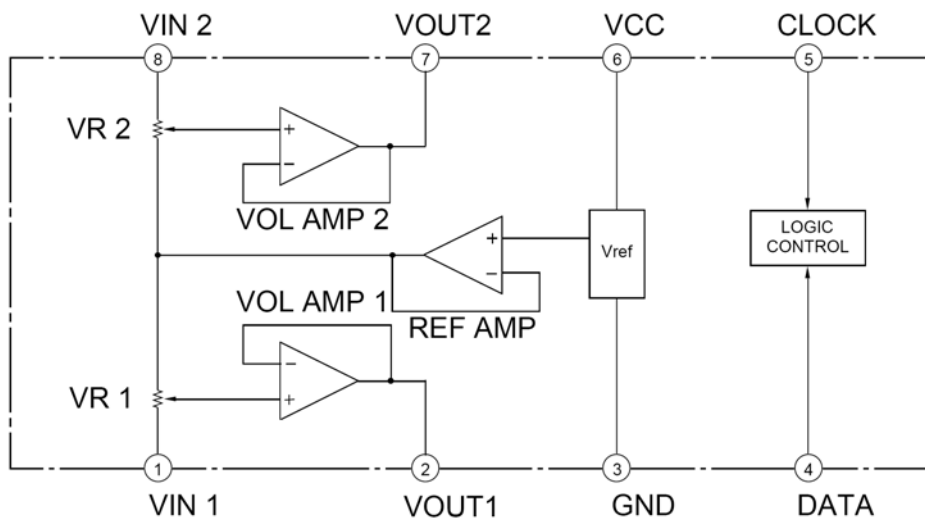

System configuration

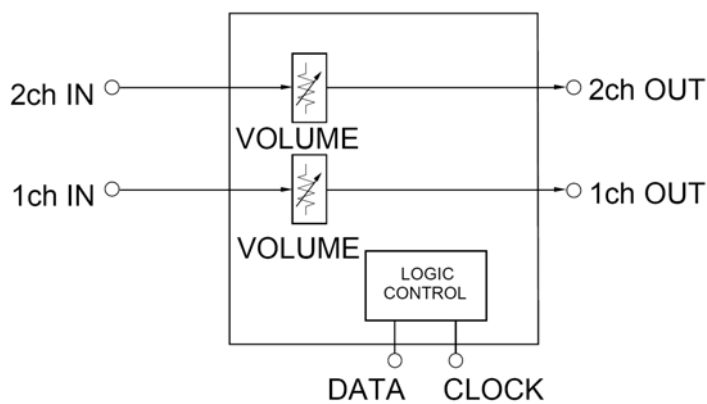

Electrical Characteristics

(V_{cc}=5V, T_A=25°C, unless otherwise noted.)

Symbol	Parameter	Test conditions	MIN °	TYP °	MAX °	UNIT
I _{cc}	Circuit current			4	8	mA
ATT	Maximum attenuation	ATT= -∞		-90	-80	dB
ATT	Attenuation error	ATT=0	-2.0	0	2.0	dB
V _{im}	Maximum input voltage	THD=1%,ATT= -6dB	1.5	1.7		V _{rms}
V _{om}	Maximum output voltage	THD=1%	0.8	1.3		V _{rms}
V _{no1}	Output noise voltage	ATT=0,R _g =0,JIS-A		4	10	μV _{rms}
V _{no2}		ATT=-∞ , R _g =0,JIS-A		5		μV _{rms}
THD	Total harmonic distortion	f=1kHz,V _o =0.5V _{rms} ,ATT=0		0.01	0.05	%
CS	Channel separation	f=1kHz,JIS-A		-80	-70	dB

Relationship Between Data and Clock

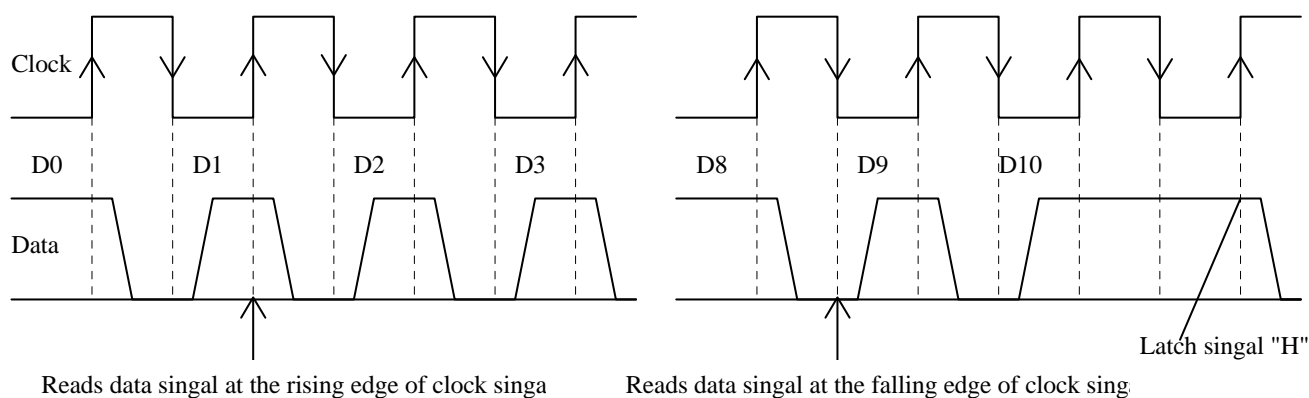

DC Characteristics of digital block

Symbol	Parameter	Test conditions	Limits			UNIT
			MIN.	TYP.	MAX.	
V _{il}	"L" level input voltage	Data, clock pin	0		0.2V _{cc}	V
V _{ih}	"H" level input voltage		0.8V _{cc}		V _{cc}	V
I _{il}	"L" level input current	V _i =0	-10		10	μA
I _{ih}	"H" level input current	V _i =5V			10	μA

AC Characteristics of digital block

Symbol	Parameter	Test conditions	Limits			Unit
			Min.	Typ.	Max.	
tcr	Cycle time of clock		4	-		us
tWHC	Pulse width of clock ("H" level)		1.6	-		us
tWLC	Pulse width of clock ("L" level)		1.6	-		us
tr	Clock rising time			-	0.4	us
tf	Clock falling time			-	0.4	us
tSD	Data setup time		0.8	-		us
tHD	Data hold time		0.8	-		us

Clock and Data Timing

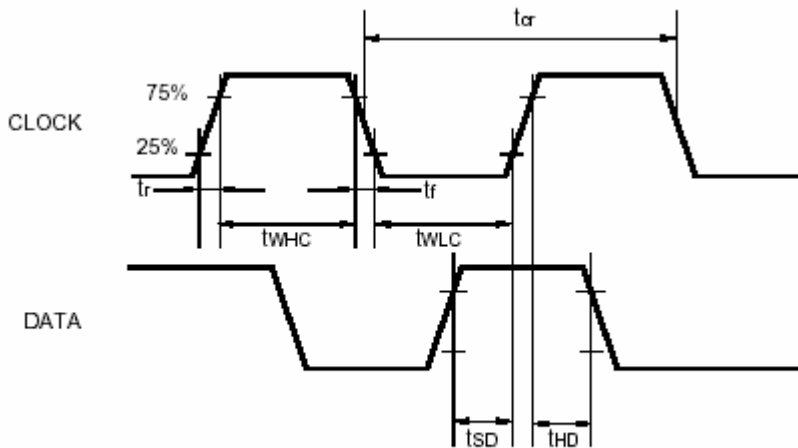

Data input format

D0	D1	D2	D3	D4	D5	D6	D7	D8	D9	D10
0/1	0/1	VOLUME						1	1	

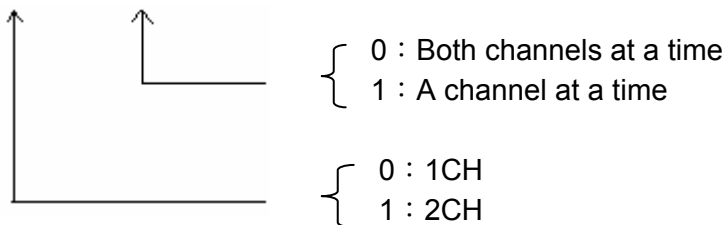

Volume Code

ATT1	D2	D3	D4	D5	D6
0 dB	1	0	1	0	1
-4 dB	0	0	1	0	1
-8 dB	1	1	0	0	1
-12 dB	0	1	0	0	1
-16 dB	1	0	0	0	1
-20 dB	0	0	0	0	1
-24 dB	1	1	1	1	0
-28 dB	0	1	1	1	0
-32 dB	1	0	1	1	0
-36 dB	0	0	1	1	0
-40 dB	1	1	0	1	0
-44 dB	0	1	0	1	0
-48 dB	1	0	0	1	0
-52 dB	0	0	0	1	0
-56 dB	1	1	1	0	0
-60 dB	0	1	1	0	0
-64 dB	1	0	1	0	0
-68 dB	0	0	1	0	0
-72 dB	1	1	0	0	0
-76 dB	0	1	0	0	0
-80 dB	1	0	0	0	0
$-\infty$	0	0	0	0	0

ATT1	D7	D8
0 dB	1	1
-1 dB	0	1
-2 dB	1	0
-3 dB	0	0

Application Example

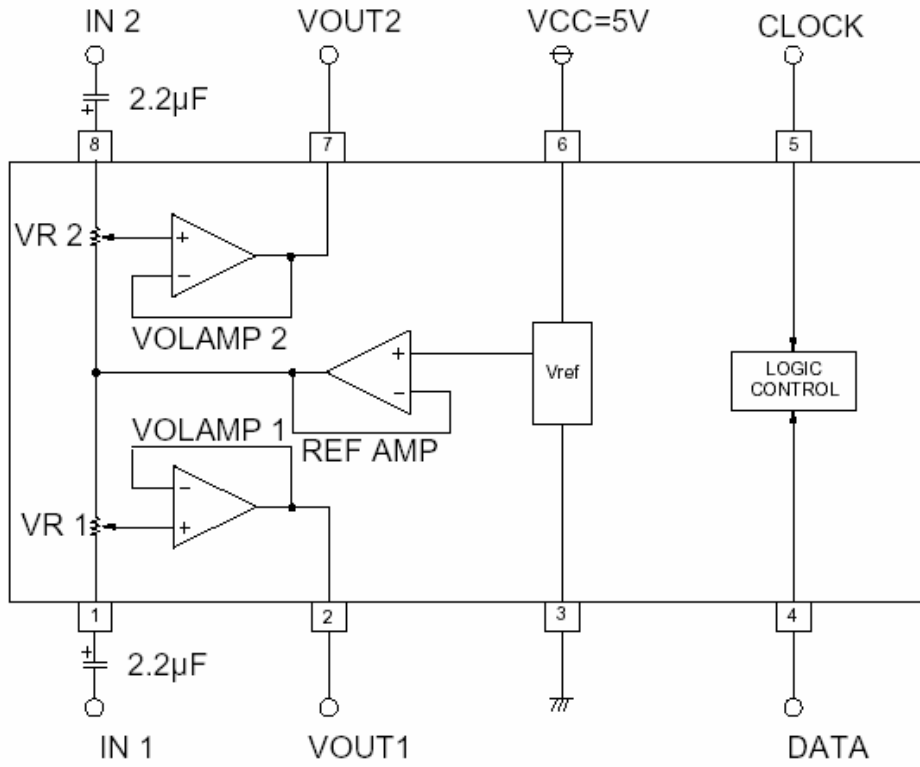

Packing Information

SOP-8

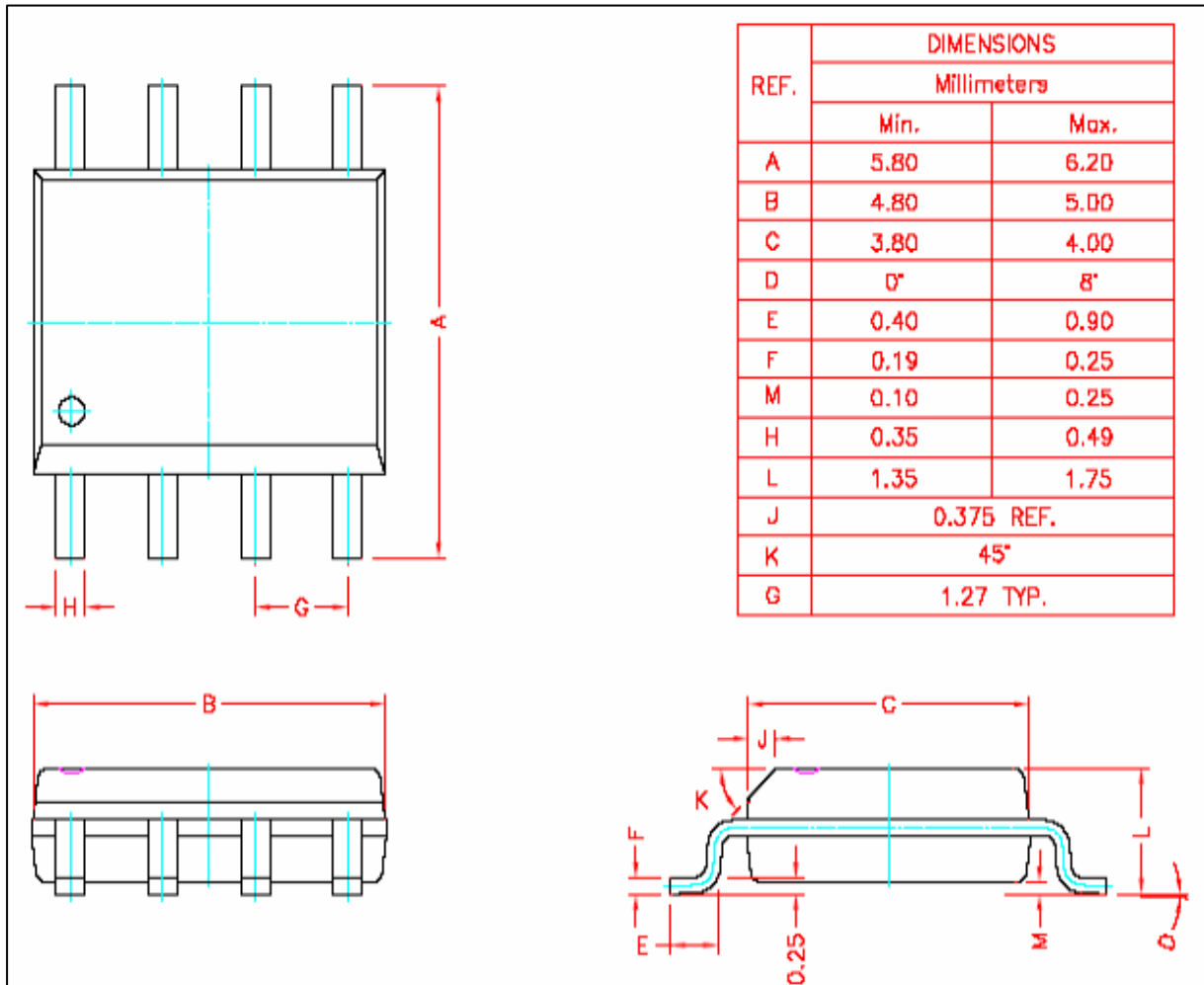

Notes

ACE does not assume any responsibility for use as critical components in life support devices or systems without the express written approval of the president and general counsel of ACE Electronics Co., LTD. As sued herein:

1. Life support devices or systems are devices or systems which, (a) are intended for surgical implant into the body, or (b) support or sustain life, and whose failure to perform when properly used in accordance with instructions for use provided in the labeling, can be reasonably expected to result in a significant injury to the user.
2. A critical component is any component of a life support device or system whose failure to perform can be reasonably expected to cause the failure of the life support device or system, or to affect its safety or effectiveness.