

Description

The ACE701 series are CMOS-based PFM step-up DC-DC Converter. The converter can start up by supply voltage as low as 0.8V, and capable of delivering maximum 200mA output current at 3.3V output with 1.8V input Voltage. Quiescent current drawn from power source is as low as 5.5uA. All of these features make ACE701 series be suitable for the portable devices, which are supplied by a single battery to four-cell batteries.

To reduce the noise caused by the switch regulator, ACE701 is well considered in circuit design and manufacture. So that the interferer to other circuits by the device is reduced greatly.

ACE701 integrates stable reference circuits and trimming technology, so it can afford high precision and low temperature-drift coefficient of the output voltage.

ACE701 is available in SOT-89-3、SOT-23-3、SOT-89-5 and SOT-23-5 packages which is PB free. And in 5-pin packages, such as SOT-23-5 and SOT-89-5, the device can be switch on or off easily by CE pin, to minimize the standby supply current.

Features

- Deliver 200mA at 3.3V Output voltage with 1.8V input Voltage
- Low start-up voltage (when the output current is 1mA)-----0.8V
- The converter output voltage can be adjusted from 2.5V~6.0V(In 0.1V step)
- Output voltage accuracy -----±2%
- Low temperature-drift coefficient of the output voltage-----±100ppm/°C
- Only three external components are necessary: An inductor, a Schottky diode and an output filter capacitor
- High power conversion efficiency---85%
- Low quiescent current drawn from power source----- <5.5uA

Application

- Power source for PDA. DSC. MP3 Player. electronic toy and wireless mouse
- Power source for a single or dual-cell battery-powered equipments
- Power source for LED

Absolute Maximum Ratings

Parameter	Symbol	Max	Unit
Input supply voltage	V _{IN}	-0.3~12	V
Input voltage	V _{I(LX)}	-0.3~V _{out} +0.3	V
CE pin voltage		-0.3~V _{out} +0.3	
Lx pin output current		0.7	A
Power Dissipation			
SOT-89-3		0.5	W
SOT-23-5		0.15	
SOT-23-3		0.15	
Junction temperature	T _J	150	°C
Storage temperature	T _S	- 40 to 125	°C
Operating free-air temperature		-20 ~ 80	°C

Packaging Type

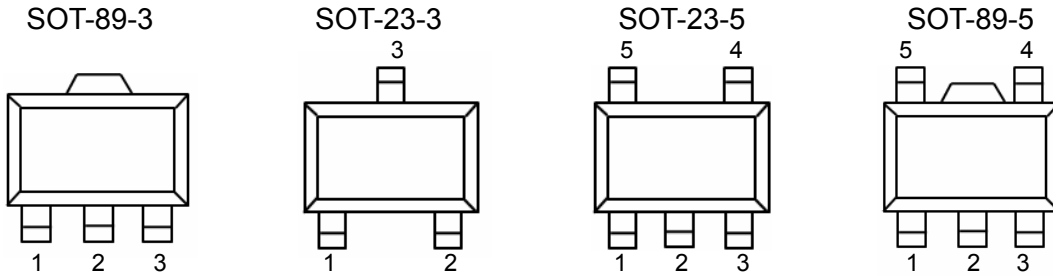

Pin	SOT-89-3	SOT-23-3	SOT-23-5	SOT-89-5	Function
V _{SS} (GND)	1	1	4	4	Ground pin
V _{OUT}	2	2	2	2	Output pin, power supply for internal circuits
L _X (Ext)	3	3	5	5	Switching pin
NC			3	3	
CE			1	1	Chip enable pin (active high)

Ordering information

Selection Guide

ACE701 X XX XX + H

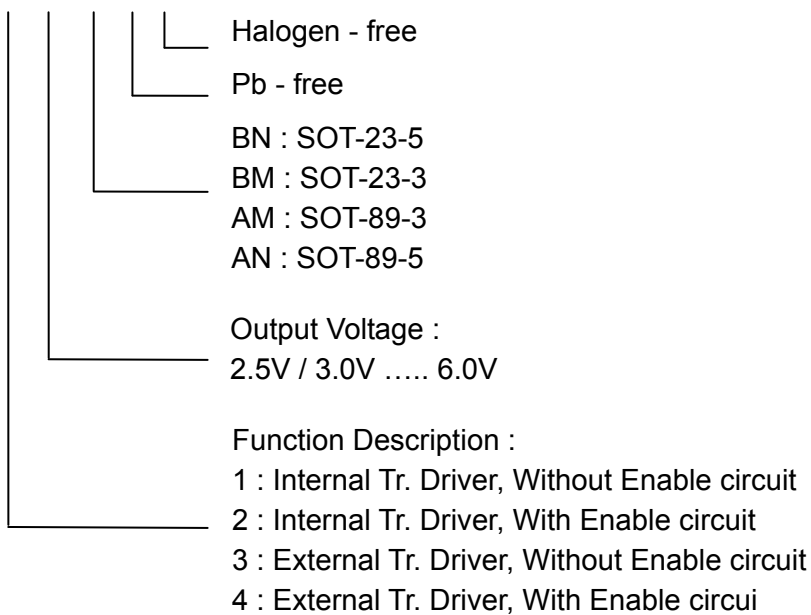

Block Diagram

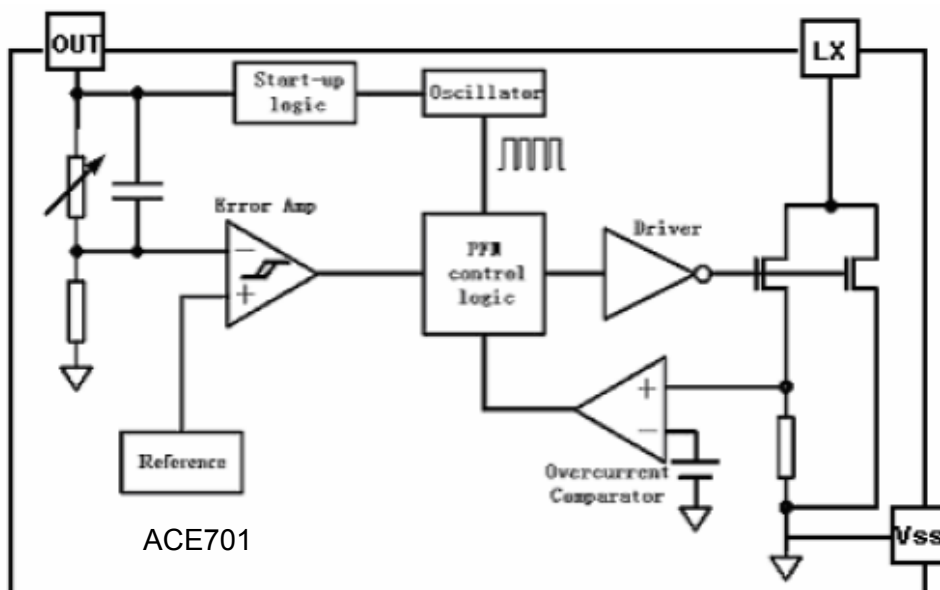

Recommended Work Conditions

Item	Min	Nom	Max	Unit
Input Voltage Range	0.8		Vout	V
Inductor	10	27	100	μH
Input capacitor	0	≥ 10		μF
Output capacitor	47	100	220	μF
Operating junction temperature	-20		85	°C

*Suggestion: Use tantalum capacitor to reduce the ripple of the output voltage.

Electrical Characteristics

Parameter	Symbol	Test Conditions	Min	Typ	Max	Unit
Output Voltage	Vout		2.45	2.5	2.55	V
			2.646	2.7	2.754	
			2.94	3.0	3.06	
			3.234	3.3	3.366	
			3.528	3.6	3.672	
			3.92	4.0	4.08	
			4.9	5.0	5.1	
			5.88	6.0	6.12	
Input Voltage	Vin				12	V
Input Current	Lin	Iout=0mA, Vin=Vout*0.6		12	15	uA
Start-up voltage	Vstart	Iout=1mA, Vin:0→2V		0.8	0.9	V
Hold-on voltage	Vhold	Iout=1mA, Vin:2→0V	0.6	0.7		V
Quiescent current drawn from power source	IDD	Without external components, Vout=Vout x 1.05		4	7	uA
Switch ON Resistance	Rswon			0.4	0.5	Ω

LX leakage current	I_{LXleak}	$V_{out}=V_{lx}=6V$			1.0	μA
CE "H" threshold voltage	V_{CEH}	$V_{CE}: 0 \rightarrow 2V$	0.6	0.9		V
CE "L" threshold voltage	V_{CEL}	$V_{CE}: 2 \rightarrow 0V$		0.3	0.6	V
Oscillator frequency	F_{OSC}	LX on "L" side $V_{out}=V_{out} * 0.96$	300	350	400	Khz
Oscillator duty cycle	Maxdty	On (V_{lx} "L") side	70	75	80	%
Efficiency	η			85		%

Note :

1. Diode: Schottky type, such as: 1N5817, 1N5819, 1N5822
2. Inductor: 27 μH ($R < 0.5\Omega$)
3. Capacitor: 100 μF (Tantalum type)

Typical Application Circuit

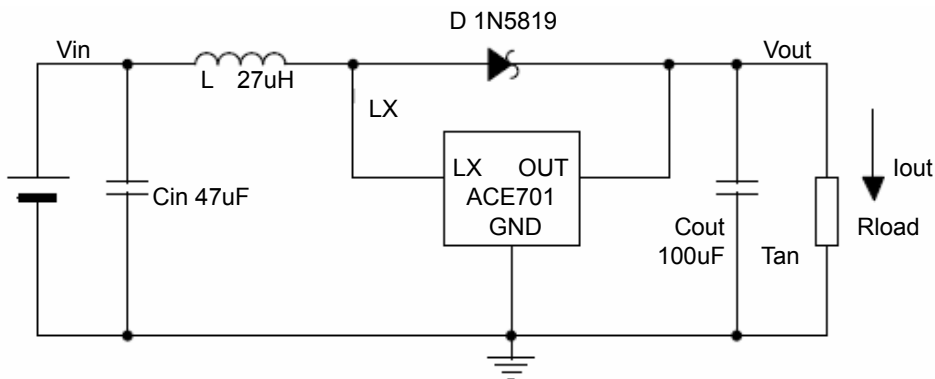

Detailed Description

The ACE701 series are boost structure, voltage-type pulse-frequency modulation(PFM) step-up DC-DC converter. Only three external components are necessary: an inductor, an output filter capacitor and a schottky diode. And the converter's low noise and low ripple output voltage can be adjusted from 2.5V to 5.0V, 0.1V step. By using the depletion technics, the quiescent current drawn from power source is lower than 7 μA . The high efficiency device consists of resistors for output voltage detection and trimming, a start-up voltage circuit, an oscillator, a reference circuit, a PFM control circuit, a switch protection circuit and a driver transistor.

The PFM control circuit is the core of the ACE701 IC. This block controls power switch on duty cycle to stabilize output voltage by calculating results of other blocks which sense input voltage, output voltage, output current and load conditions. In PFM modulation system, the frequency and pulse width is fixed. The duty cycle is adjusted by skipping pulses, so that switch on-time is changed based on the conditions such as input voltage, output current and load. The oscillate block inside ACE701 provides fixed frequency and pulse width wave.

The reference circuit provides stable reference voltage to output stable output voltage. Because internal trimming technology is used, The chip output change less than $\pm 2\%$. At the same time , the problem of temperature-drift coefficient of output voltage is considered in design, so temperature-drift coefficient of output voltage is less than 100ppm/ $^{\circ}C$.

High-gain differential error amplifier guarantees stable output voltage at difference input voltage and load. In order to reduce ripple and noise, the error amplifier is designed with high band-width.

Though at very low load condition, the quiescent current of chip do effect efficiency certainly. The four main energy loss of Boost structure DC-DC converter in full load are the ESR of inductor, the voltage of Schottky diode, on resistor of internal N-channel MOSFET and its driver. In order to improve the efficiency, ACE701 integrates low on-resistor N-channel MOSFET and well design driver circuits. The switch energy loss is limited at very low level.

Selection of the External Components

Thus it can be seen, the inductor and schottky diode affect the conversion efficiency greatly. The inductor and the capacitor also have great influence on the output voltage ripple of the converter. So it is necessary to choose a suitable inductor, a capacitor and a right schottky diode, to obtain high efficiency, low ripple and low noise.

Before discussion , we define $D \equiv V_{out} - V_{in} / V_{out}$

(1) Inductor Selection

Above all, we should define the minimum value of the inductor that can ensure the boost DC-DC to operate in the continuous current-mode condition.

$$L_{min} \geq D(1-D)^2 R_L / 2f$$

The above expression is got under conditions of continuous current mode, neglect Schottky diode's voltage, ESR of both inductor and capacitor. The actual value is greater that it. If inductor's value is less than L_{min} , the efficiency of DC-DC converter will drop greatly, and the DC-DC circuit will not be stable.

Secondly, consider the ripple of the output voltage,

$$\Delta I = D \cdot V_{in} / Lf$$

$$I_{max} = V_{in} / (1-D)^2 R_L + D V_{in} / 2Lf$$

If inductor value is too small, the current ripple through it will be great. Then the current through diode and power switch will be great. Because the power switch on chip is not ideal switch, the energy of switch will improve. The efficiency will fall.

Thirdly , in general, smaller inductor values supply more output current while larger values start up with lower input voltage and acquire high efficiency.

An inductor value of 3uH to 1mH works well in most applications. If DC-DC converter delivers large output current (for example: output current is great than 50mA), large inductor value is recommended in order to improve efficiency. If DC-DC must output very large current at low input supply voltage, small inductor value is recommended.

The ESR of inductor will effect efficiency greatly. Suppose ESR value of inductor is r_L , R_{load} is load resistor , then the energy can be calculated by following expression:

$$\Delta \eta \approx R_L / R_{load} (1-D)^2$$

For example: input 1.5V, output is 3.0V, $R_{load}=20\Omega$, $r_L=0.5\Omega$, The energy loss is 10%.

Consider all above, inductor value of 47uH, ESR<0.5Ω is recommended in most applications. Large value is recommended in high efficiency applications and smaller value is recommended

(2)Capacitor Selection

Ignore ESR of capacitor, the ripple of output voltage is:

$$R = \Delta V_{out} / V_{out} = D / R_{load} C_f$$

So large value capacitor is needed to reduce ripple. But too large capacitor value will slow down system reaction and cost will improve. So 100uF capacitor is recommended. Larger capacitor value will be used in large output current system. If output current is small (<10mA), small value is needed.

Consider ESR of capacitor, ripple will increase :

$$r' = r + I_{max} \cdot R_{ESR} / V_{out}$$

When current is large, ripple caused by ESR will be main factor. It may be greater than 100mV. The ESR will affect efficiency and increase energy loss. So low-ESR capacitor (for example: tantalum capacitor) is recommended or connect two or more filter capacitors in parallel.

(3)Diode Selection

Rectifier diode will affect efficiency greatly, Though a common diode (such as 1N4148) will work well for light load, it will reduce about 5%~10% efficiency for heavy load. For optimum performance, a Schottky diode (such as 1N5817, 1N5819, 1N5822) is recommended.

(4)Input Capacitor

If supply voltage is stable, the DC-DC circuit can output low ripple, low noise and stable voltage without input capacitor. If voltage source is far away from DC-DC circuit, input capacitor value greater than 10uF is recommended.

Test Circuits

(1) Output voltage test circuit ($I_{load}=1mA$)

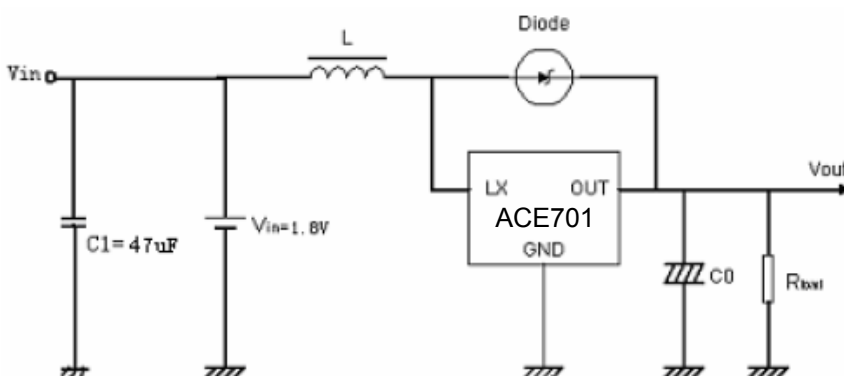

(2) Start-up voltage test circuit ($I_{load}=1mA$)

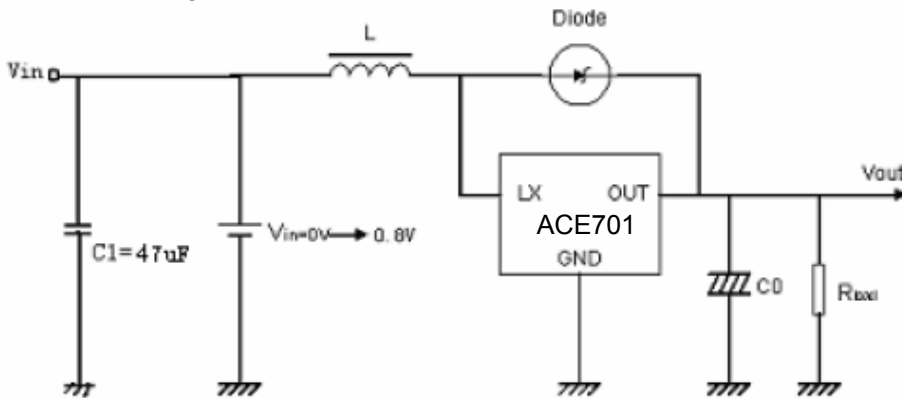

(3) Hold-on voltage test circuit ($I_{load}=1mA$)

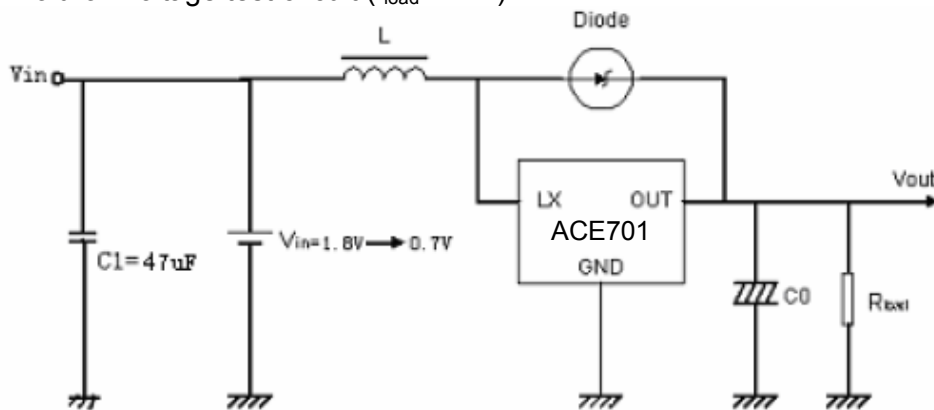

(4) Quiescent current test circuit

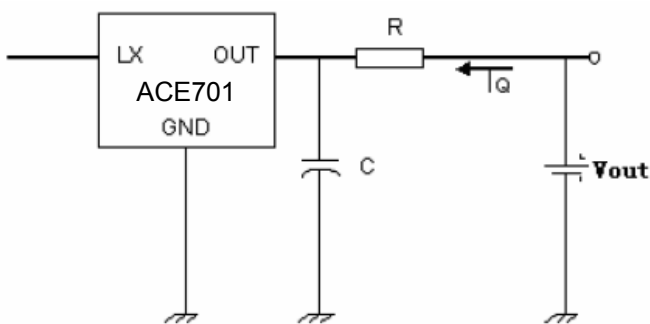

Note: $V_{out} = V_{out} * 1.05$, $R = 1K\Omega$, $C = 0.1\mu F$

(5) Oscillator frequency and duty cycle test circuit

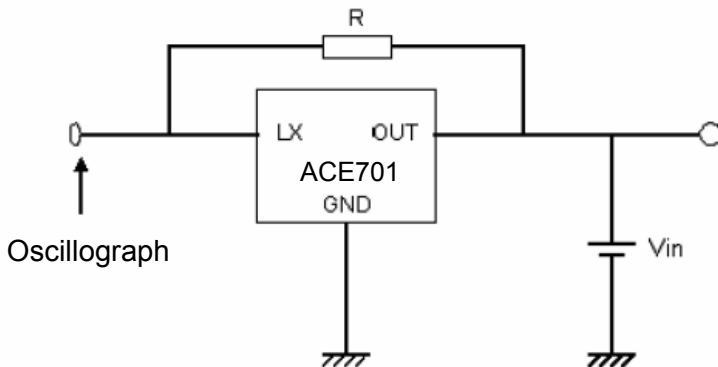

Note: $V_{in} = V_{out} * 0.95$, $R = 1K\Omega$

Typical Characteristic

(Recommended operating conditions: $C_{in} = 47\mu F$, $C_{out} = 47\mu F$, $T_{opt} = 25^\circ C$, unless otherwise noted)

1. Output Voltage VS. Output Current

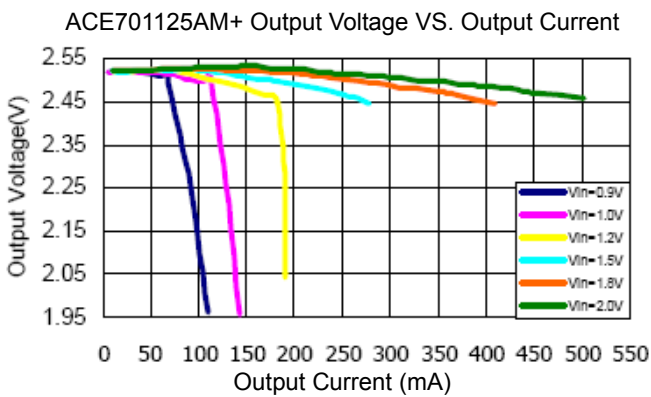

2. Output Voltage VS. Output Current

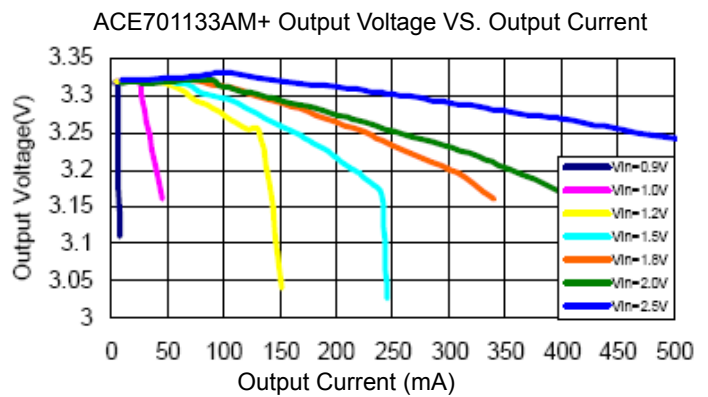

3. Output Voltage VS. Output Current

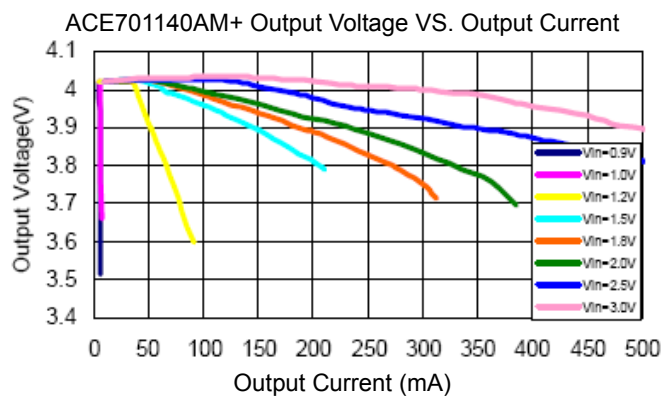

4. Efficiency VS. Output Current

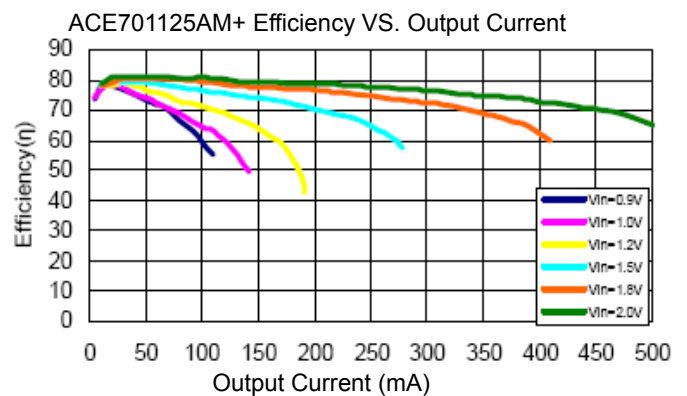

5. Efficiency VS. Output Current

ACE701133AM+ Efficiency VS. Output Current

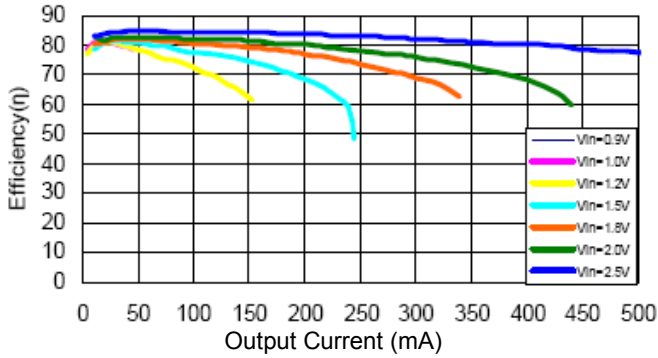

6. Efficiency VS. Output Current

ACE701140AM+ Efficiency VS. Output Current

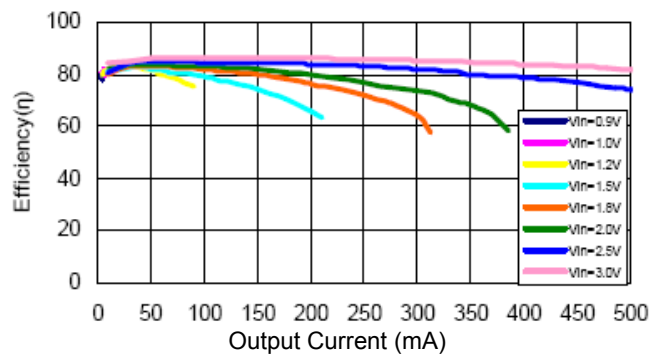

7. Ripple VS. Output Current

ACE701125AM+ Ripple Voltage VS. Output Current

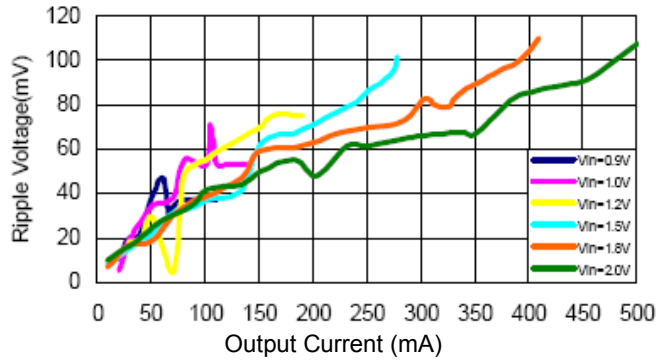

8. Ripple VS. Output Current

ACE701133AM+ Ripple Voltage VS. Output Current

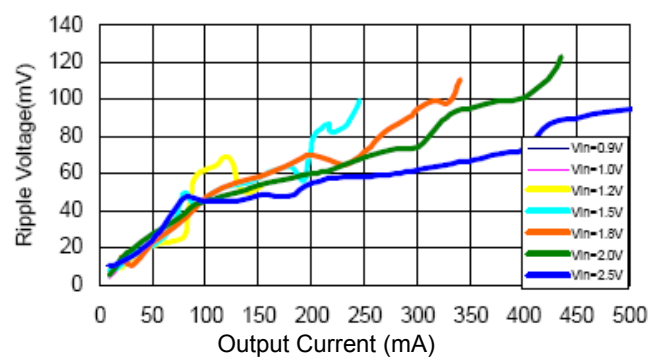

9. Ripple VS. Output Current

ACE701140AM+ Ripple Voltage VS. Output Current

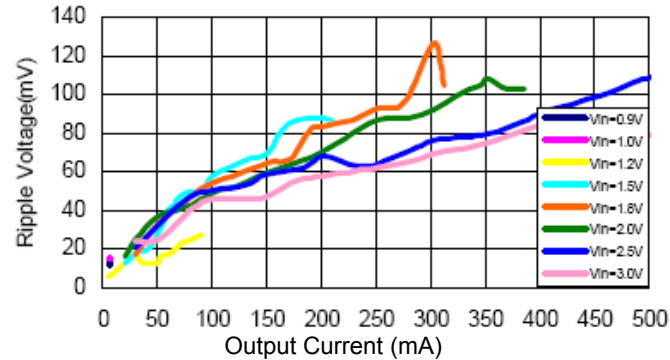

10. I_{no load} VS. Input Voltage

ACE701 Quiescent Current (I_{no load}) VS. Input Voltage

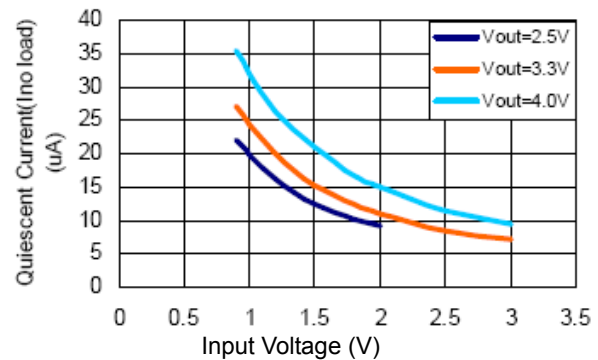

Packing Information

SOT-89-3

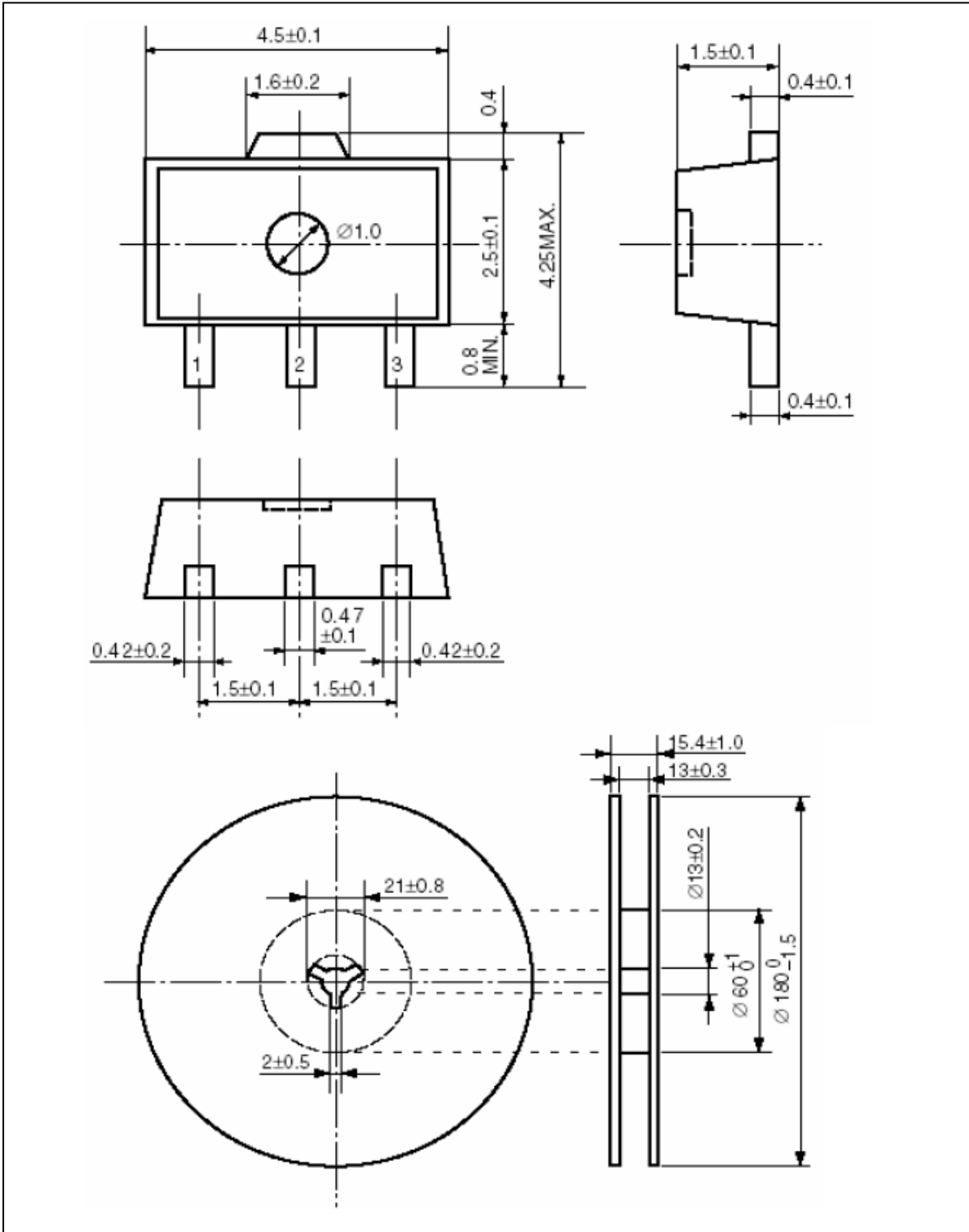

Packing Information

SOT-23-3

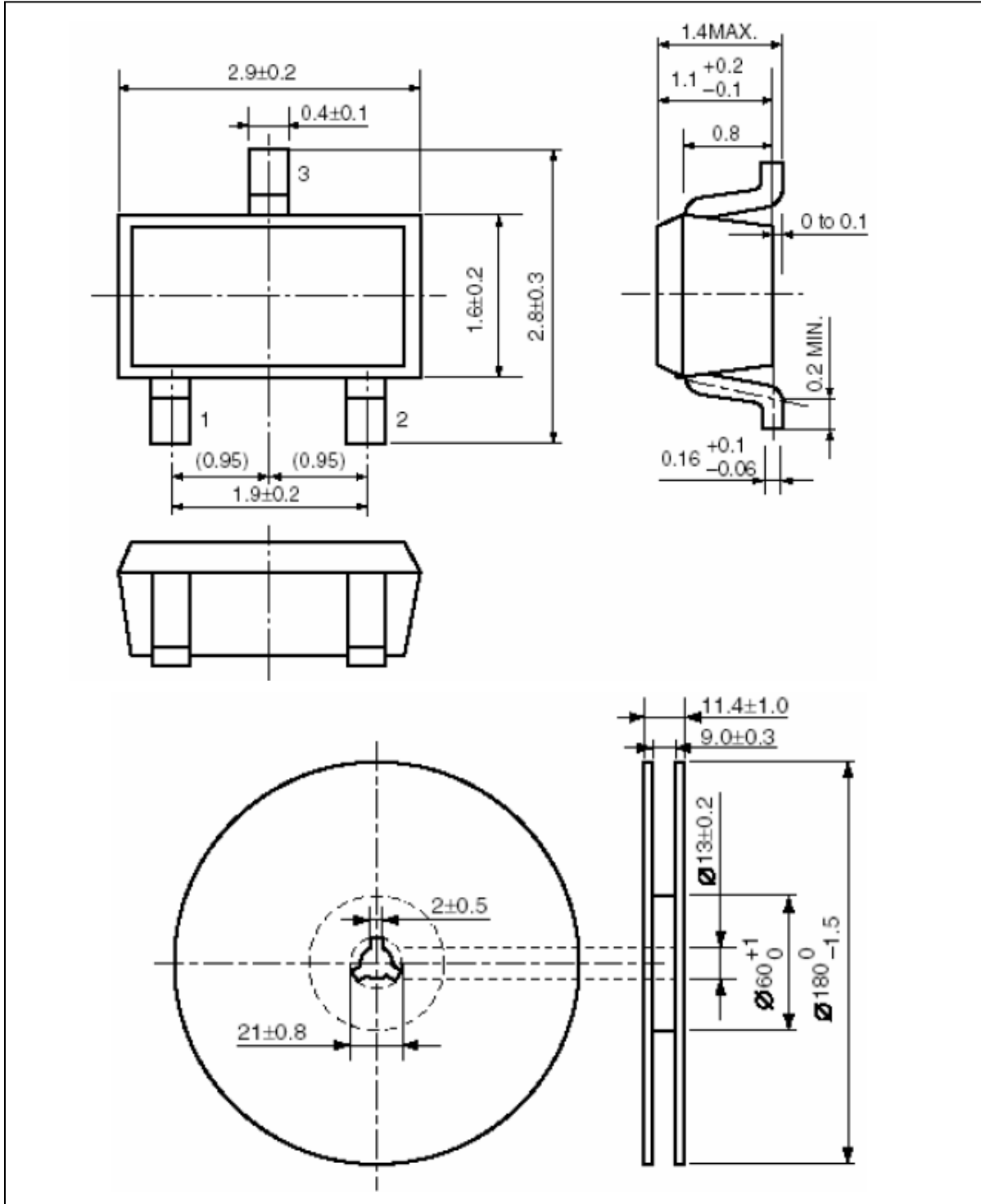

Packing Information

SOT-23-5

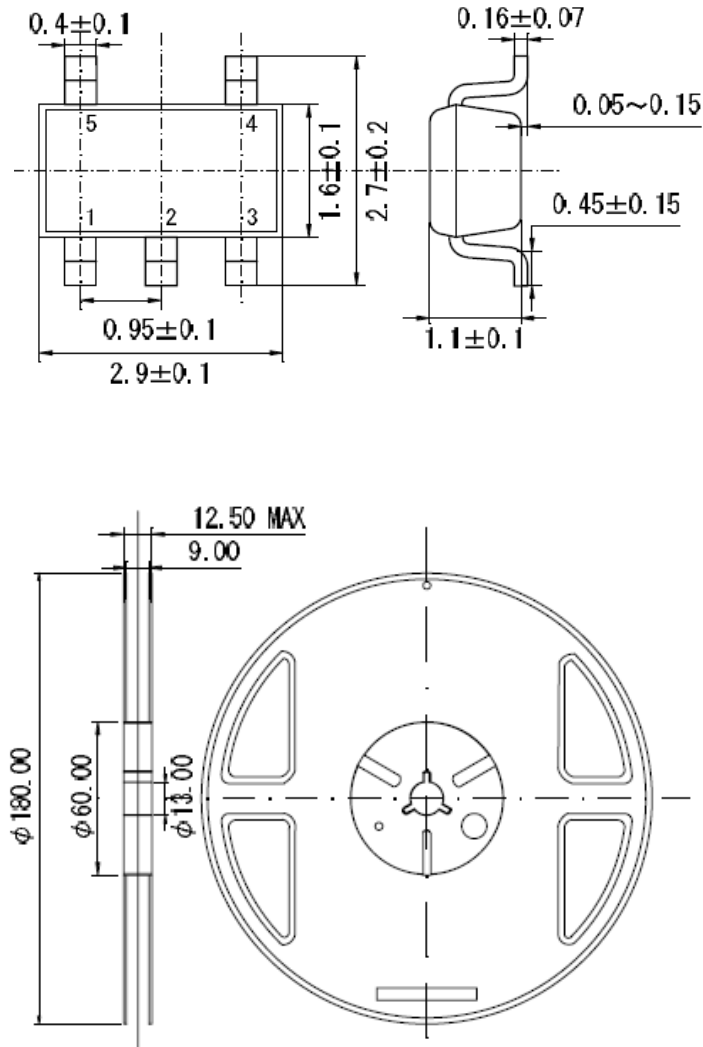

Packing Information

SOT-89-5

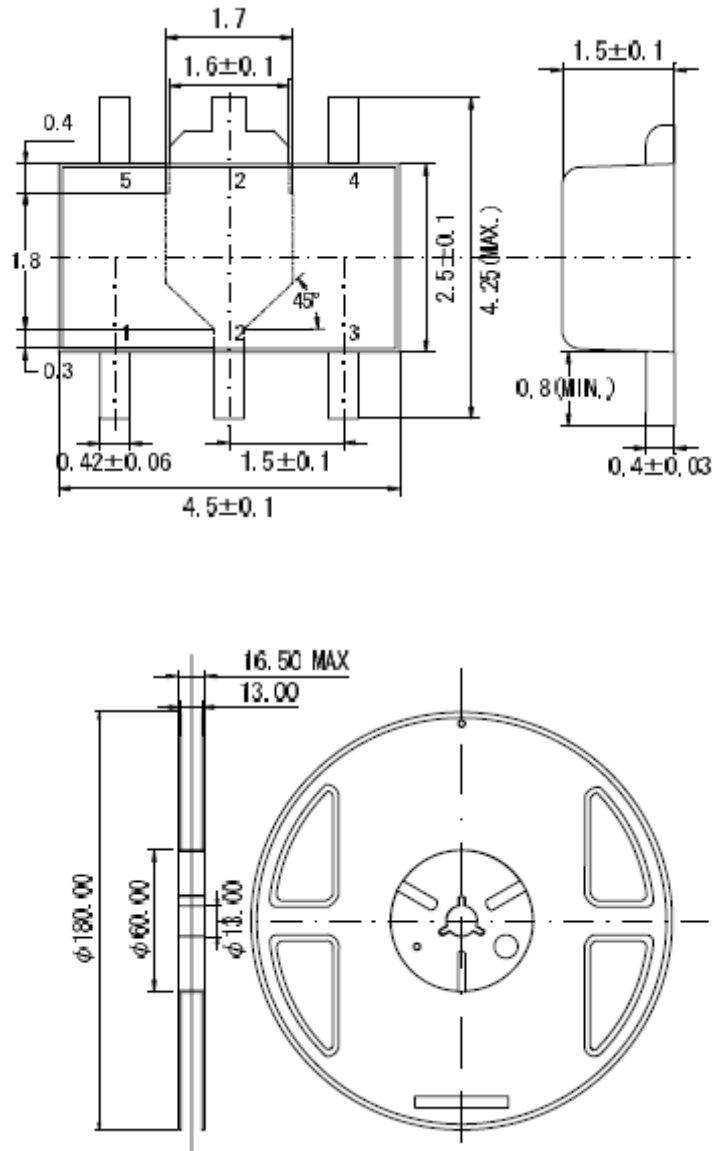

Notes

ACE does not assume any responsibility for use as critical components in life support devices or systems without the express written approval of the president and general counsel of ACE Electronics Co., LTD. As sued herein:

1. Life support devices or systems are devices or systems which, (a) are intended for surgical implant into the body, or (b) support or sustain life, and whose failure to perform when properly used in accordance with instructions for use provided in the labeling, can be reasonably expected to result in a significant injury to the user.
2. A critical component is any component of a life support device or system whose failure to perform can be reasonably expected to cause the failure of the life support device or system, or to affect its safety or effectiveness.