



ACE7215C

1.5A 1.5MHz Synchronous Buck Converter

Description

The ACE7215C is a high-efficiency monolithic synchronous buck regulator using a constant frequency, current mode architecture. The device is available in an adjustable version. Supply current with no load is 40uA and drops to <1uA in shutdown. The 2.5V to 6V input voltage range makes the ACE7215C ideally suited for single Li-Ion battery powered applications. 100% duty cycle provides low dropout operation, extending battery life in portable systems. PWM/PFM mode operation provides very low output ripple voltage for noise sensitive applications.

Switching frequency is internally set at 1.5MHz, allowing the use of small surface mount inductors and capacitors. Low output voltages are easily supported with the 0.6V feedback reference voltage.

The ACE7215C is available in SOT23-5 and DFN2*2-6L package.

Features

- High Efficiency: Up to 96%
- 2.5V to 6V Input Voltage Range
- 1.5MHz Constant Frequency Operation
- No Schottky Diode Required
- Low Dropout Operation:100% Duty Cycle
- PFM Mode for High Efficiency in Light Load
- Over temperature Protected
- Low Quiescent Current: 40μA
- Short Circuit Protection
- Inrush Current Limit and Soft Start
- Available in SOT23-5 and DFN2*2-6L

Application

- Cellular and Smart Phones
- Wireless and DSL Modems
- PDAs
- Portable Instruments
- Digital Still and Video Cameras
- PC Cards



ACE7215C

1.5A 1.5MHz Synchronous Buck Converter

Absolute Maximum Ratings

Parameter		Value
Max Input Voltage		7V
Max Voltage All Pins		7V
Max Operating Junction Temperature(Tj)		125°C
Ambient Temperature(Ta)		-40°C ~85°C
Maximum Power Dissipation	SOT23-5	400mW
	DFN2*2-6L	600mW
Storage Temperature(Ts)		-40°C ~50°C
Lead Temperature & Time		260°C, 10S

Note: Exceed these limits to damage to the device. Exposure to absolute maximum rating conditions may affect device reliability.

Packaging Type

SOT23-5

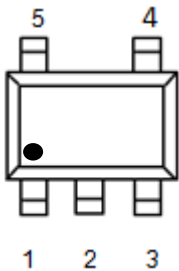

DFN2*2-6L

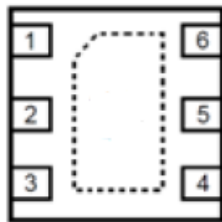

PIN NO		Description	Description
SOT23-5	DFN2*2-6L		
1	2	EN	Chip Enable Pin. Drive EN above 1.5V to turn on the part. Drive EN below 0.3V to turn it off. Do not leave EN floating.
2	1/5/7	GND	Ground
3	4	SW	Power Switch Output. It is the switch node connection to Inductor. This pin connects to the drains of the internal P-ch and N-ch MOSFET switches.
4	3	VIN	Supply voltage. Must be closely decoupled to GND with a 10μF or greater ceramic capacitor.
5	6	FB	Output Voltage Feedback Pin. An internal resistive divider divides the output voltage down for comparison to the internal reference voltage.

Ordering information

ACE7215CXX+ H

Halogen - free

Pb - free

BN : SOT23-5

MN : DFN2*2-6L



ACE7215C 1.5A 1.5MHz Synchronous Buck Converter

Typical Application

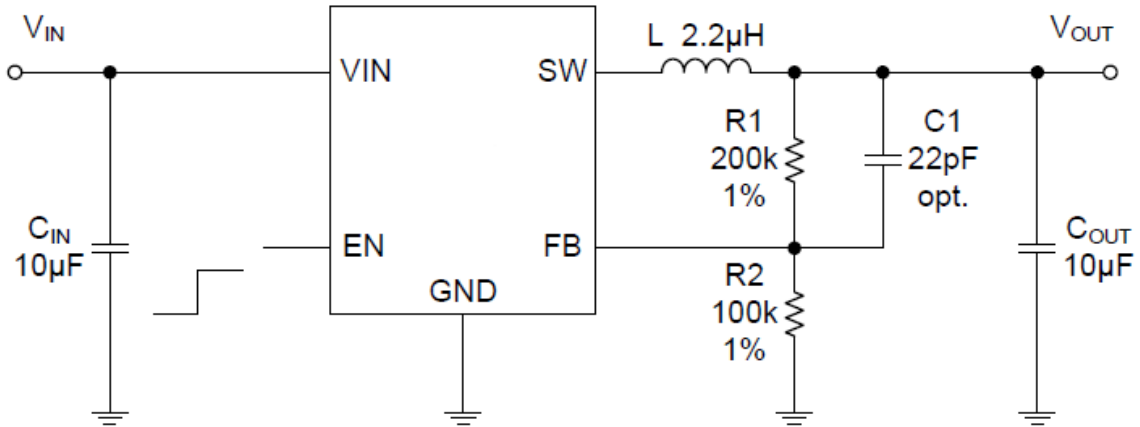

Block Diagram

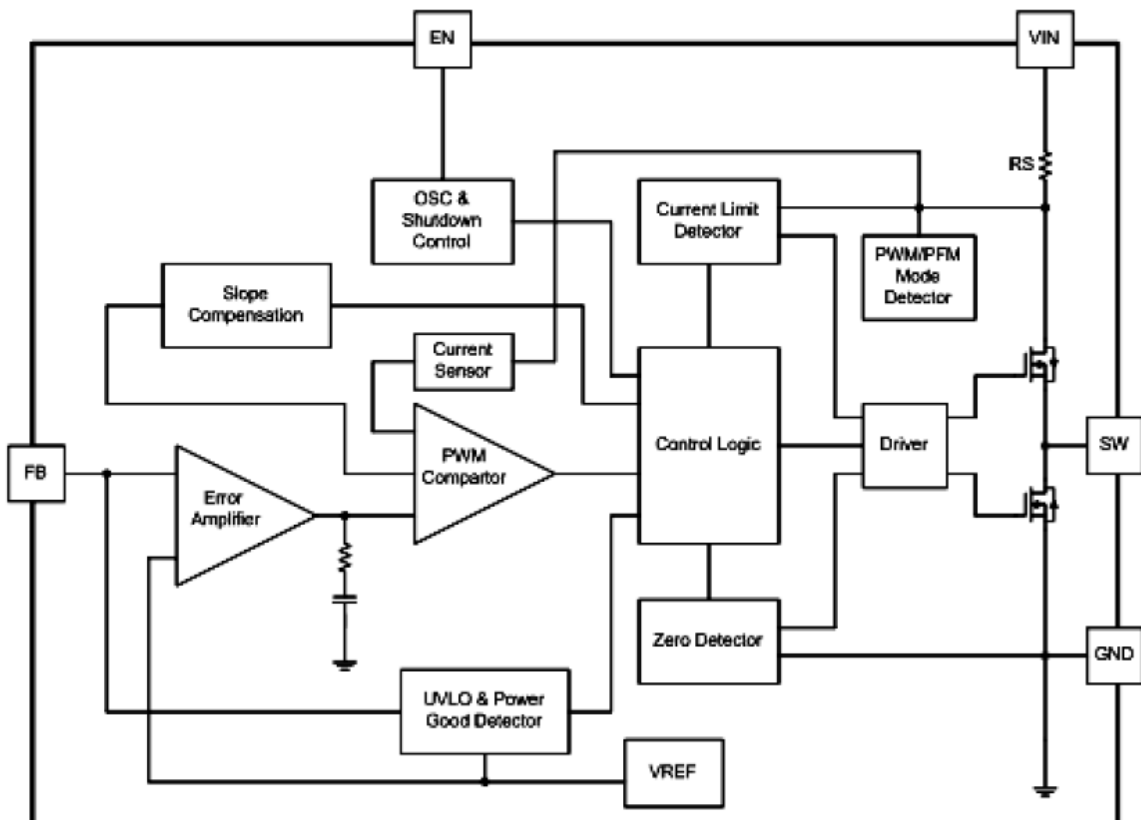



ACE7215C

1.5A 1.5MHz Synchronous Buck Converter

Electrical Characteristics

Symbol	Parameter	Conditions	Min	Typ	Max	Unit
V _{in}	Input Voltage Range		2.5		6	V
V _{ref}	Feedback Voltage		0.588	0.6	0.612	V
I _q	Quiescent Current	FB=90%, V _{in} =5.0V, I _{load} =0mA		150	300	uA
		FB= 05%, V _{in} =5.0V, I _{load} =0mA		40	70	
		V _{EN} =0V, V _{in} =4.2V		0.1	1.0	
LnReg	Line Regulation	V _{in} =2.5V to 6V		0.1	0.2	%/V
LdReg	Load Regulation			0.5		%
F _{sw}	Switching Frequency			1.5		MHz
R _{dsonP}	PMOS R _{dson}	I _{sw} =100mA		300		mohm
R _{dsonN}	NMOS R _{dson}	I _{sw} =-100mA		200		mohm
I _{limit}	Peak Current Limit	V _{in} =5V, V _{out} =3.3V		1.5		A
I _{nload} *		V _{in} =5V, V _{out} =3.3V, I _{out} =0		43		uA
I _{swlk}	SW Leakage Current	V _{EN} =0V, V _{in} =V _{sw} =5V			1	uA
I _{enlk}	EN Leakage Current				1	uA
V _{h_en}	EN Input High Voltage		1.04			V
V _{l_en}	EN Input Low Voltage				0.98	V

Note: *When Duty cycle >90%, I_{nload} will increase. e.g. V_{in}=3.5V/V_{out}=3.3V, I_{nload}=800uA.



ACE7215C

1.5A 1.5MHz Synchronous Buck Converter

Detailed Description

The ACE7215C uses a constant frequency, current mode step-down architecture. Both the main (P-channel MOSFET) and synchronous (N-channel MOSFET) switches are internal. During normal operation, the internal top power MOSFET is turned on each cycle when the oscillator sets the RS latch, and turned off when the current comparator, ICOMP, resets the RS latch. The peak inductor current at which ICOMP resets the RS latch, is controlled by the output of error amplifier EA. When the load current increases, it causes a slight decrease in the feedback voltage, FB, relative to the 0.6V reference, which in turn, causes the EA amplifier's output voltage to increase until the average inductor current matches the new load current. While the top MOSFET is off, the bottom MOSFET is turned on until either the inductor current starts to reverse, as indicated by the current reversal comparator IRCMP, or the beginning of the next clock cycle.

Applications Information

Setting the Output Voltage

In the adjustable version, the output voltage is set by a resistive divider according to the following formula:

$$R_2 = \frac{R_1}{V_{out} / V_{FB} - 1}$$

The external resistive divider is connected to the output, allowing remote voltage sensing as shown in on page 1.

Inductor Selection

For most designs, the ACE7215C operates with inductors of 1μH to 4.7μH. Low inductance values are physically smaller but require faster switching, which results in some efficiency loss. The inductor value can be derived from the following equation:

$$L = \frac{V_{OUT} \times (V_{IN} - V_{OUT})}{V_{IN} \times \Delta I_L \times f_{OSC}}$$

Where ΔI_L is inductor Ripple Current. Large value inductors result in lower ripple current and small value inductors result in high ripple current. For optimum voltage-positioning load transients, choose an inductor with DC series resistance in the 50mΩ to 150mΩ range.



ACE7215C

1.5A 1.5MHz Synchronous Buck Converter

Input Capacitor Selection

Higher values, lower cost ceramic capacitors are now becoming available in smaller case sizes. Their high ripple current, high voltage rating and low ESR make them ideal for switching regulator applications. Because the ACE7215C's control loop does not depend on the output capacitor's ESR for stable operation, ceramic capacitors can be used freely to achieve very low output ripple and small circuit size. However, care must be taken when ceramic capacitors are used at the input and the output. When a ceramic capacitor is used at the input and the power is supplied by a wall adapter through long wires, a load step at the output can induce ringing at the input, VIN. At best, this ringing can couple to the output and be mistaken as loop instability. At worst, a sudden inrush of current through the long wires can potentially cause a voltage spike at VIN, large enough to damage the part. When choosing the input and output ceramic capacitors, choose the X5R or X7R dielectric formulations. These dielectrics have the best temperature and voltage characteristics of all the ceramics for a given value and size.

PC Board Layout Checklist

When laying out the printed circuit board, the following checking should be used to ensure proper operation of the ACE7215C. Check the following in your layout:

1. The power traces, consisting of the GND trace, the SW trace and the VIN trace should be kept short, direct and wide.
2. Does the (+) plates of Cin connect to Vin as closely as possible? This capacitor provides the AC current to the internal power MOSFETs.
3. Keep the switching node, SW, away from the sensitive VOUT node.
4. Keep the (-) plates of Cin and Cout as close as possible



ACE7215C 1.5A 1.5MHz Synchronous Buck Converter

Electrical Performance

Tested under $T_A=25^{\circ}\text{C}$, unless otherwise specified

Efficiency vs. Output Current ($V_{out}=1.2\text{V}$)

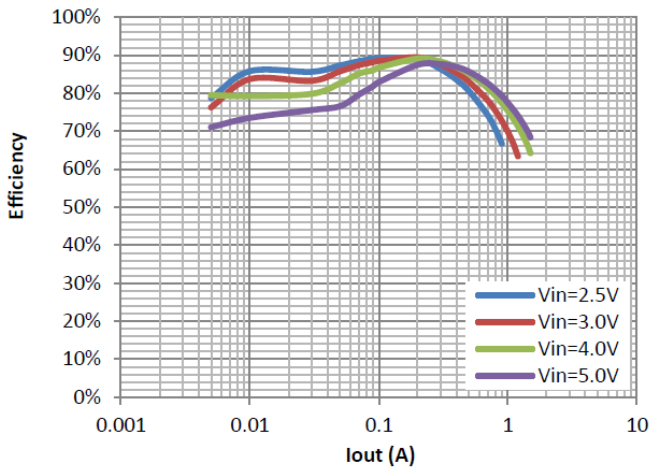

Efficiency vs. Output Current ($V_{out}=1.8\text{V}$)

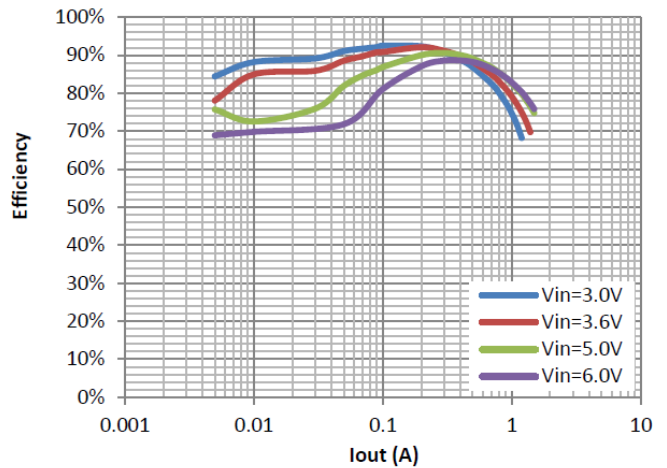

Efficiency vs. Output Current ($V_{out}=3.3\text{V}$)

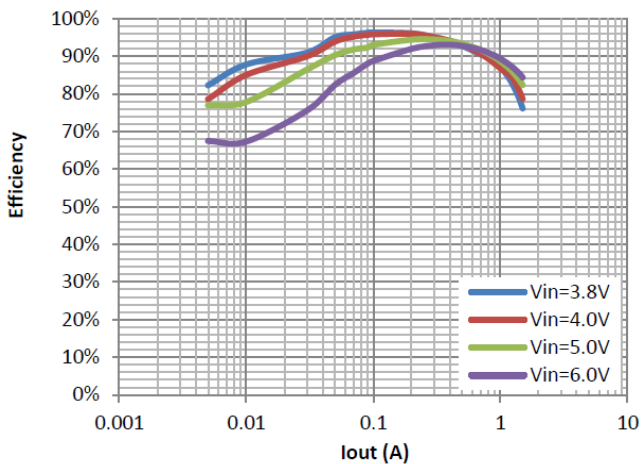

Output Ripple and SW at 1.5A load $V_{in}=5\text{V} / V_{out}=3.3\text{V}$

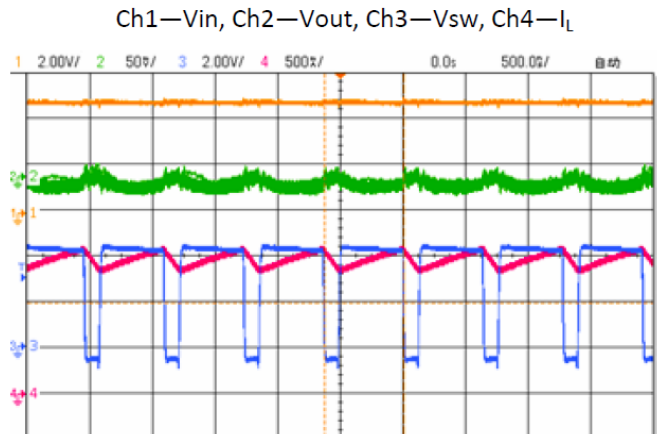



ACE7215C

1.5A 1.5MHz Synchronous Buck Converter

Packing Information

SOT23-5

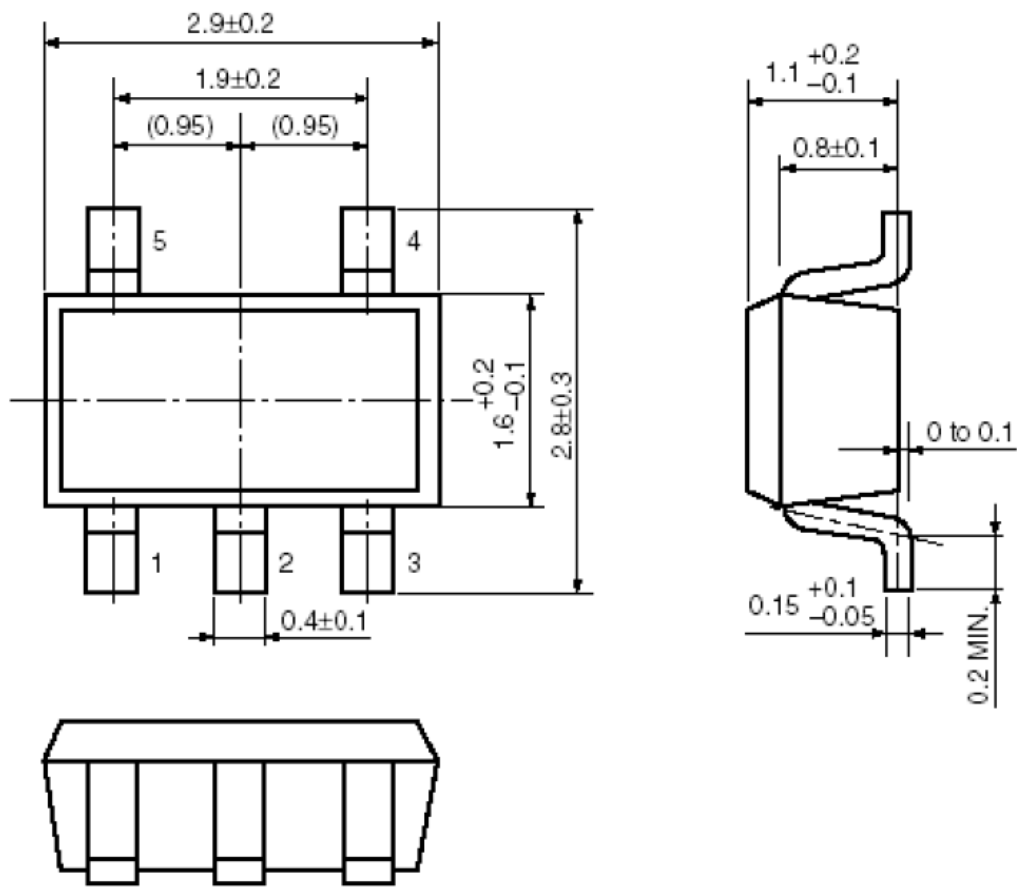

UNIT: mm



ACE7215C 1.5A 1.5MHz Synchronous Buck Converter

Packing Information

DFN2*2-6L

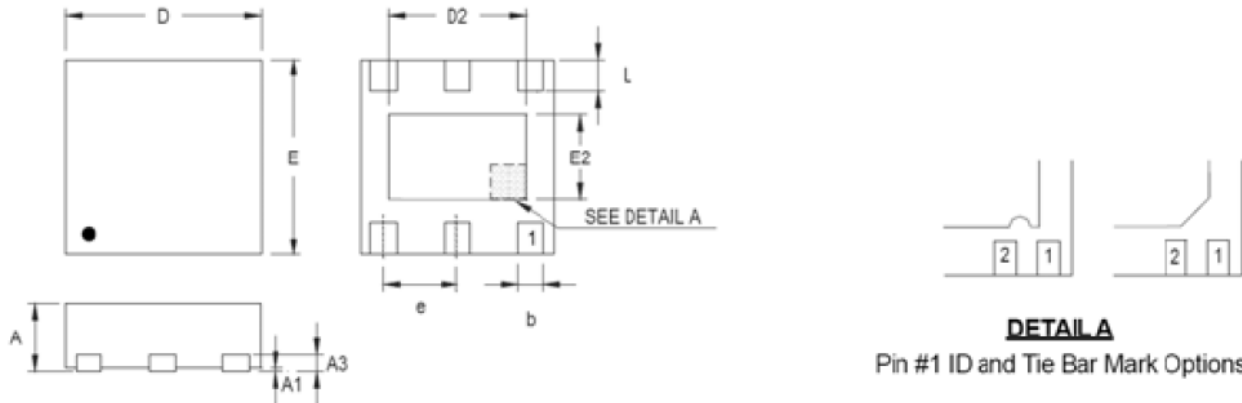

DETAIL A
Pin #1 ID and Tie Bar Mark Options

Note : The configuration of the Pin #1 identifier is optional, but must be located within the zone indicated.

Symbol	Dimensions In Millimeters		Dimensions In Inches	
	Min	Max	Min	Max
A	0.700	0.800	0.028	0.031
A1	0.000	0.050	0.000	0.002
A3	0.175	0.250	0.007	0.010
b	0.200	0.350	0.008	0.014
D	1.950	2.050	0.077	0.081
D2	1.000	1.450	0.039	0.057
E	1.950	2.050	0.077	0.081
E2	0.500	0.850	0.020	0.033
e	0.650		0.026	
L	0.300	0.400	0.012	0.016



ACE7215C

1.5A 1.5MHz Synchronous Buck Converter

Notes

ACE does not assume any responsibility for use as critical components in life support devices or systems without the express written approval of the president and general counsel of ACE Electronics Co., LTD. As used herein:

1. Life support devices or systems are devices or systems which, (a) are intended for surgical implant into the body, or (b) support or sustain life, and whose failure to perform when properly used in accordance with instructions for use provided in the labeling, can be reasonably expected to result in a significant injury to the user.
2. A critical component is any component of a life support device or system whose failure to perform can be reasonably expected to cause the failure of the life support device or system, or to affect its safety or effectiveness.

ACE Technology Co., LTD.
<http://www.ace-ele.com/>