

Description

The ACE723 is a high efficiency synchronous, buck DC/DC converter. Its input voltage range is from 2.6V to 5.5V and provides an adjustable regulated output voltage from 0.8V to 5.5V while delivering up to 3A of output current.

The internal synchronous switches efficiency and eliminate the need for an external Schottky diode. The switching frequency is set by an external resistor or can be synchronized to an external clock. The 100% duty cycle provides low dropout operation extending battery life in portable systems.

The ACE723 is operated in forced continuous PWM Mode which minimizes ripple voltage and reduces the noise and RF interference.

Features

- Adjustable Output Voltage, $V_{fb}=0.8V$
- Maximum output current is 3A
- Range of operation input voltage: Max 5.5V
- Standby current: 0.5mA (typ.)
- Line Regulation: 0.1%/V (typ.)
- Load Regulation: 10mV (typ.)
- High efficiency, up to 96%
- Environment Temperature: $-20^{\circ}C \sim 85^{\circ}C$

Application

- Power Management for 3G modem
- 3W LED driver from Li-ion battery
- LCD Monitor and LCD TV
- DVD Decode Board
- ADSL Modem
- Post Regulators for Switching Supplies

Typical Application

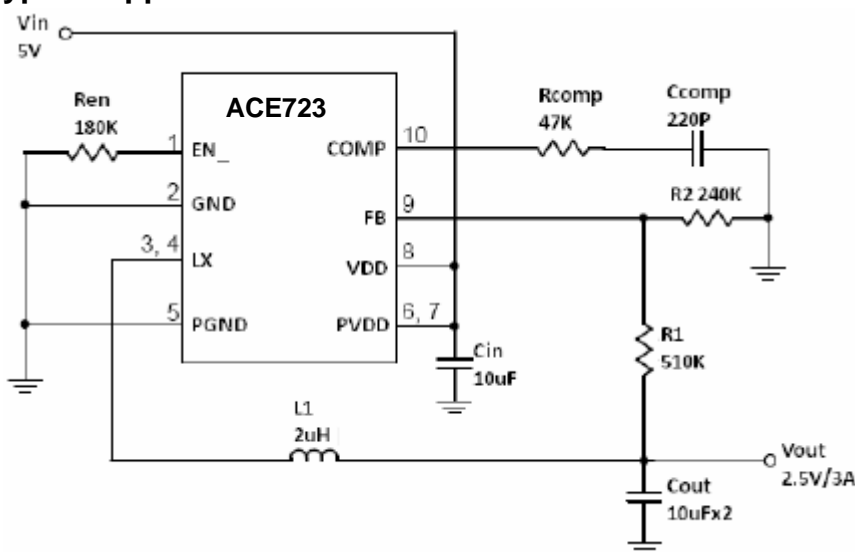

Absolute Maximum Ratings

Parameter	Symbol	Max	Unit
Input voltage	V_{IN}	5.5	V
Operating Junction Temperature	T_J	125	°C
Ambient Temperature	T_A	-20 ~85	°C
Package Thermal Resistance DFN 3*3-10		-20	°C/W
Storage temperature	T_S	- 40 to 150	°C
ESD (HBM)		>2000	V

Note: Exceed these limits to damage to the device. Exposure to absolute maximum rating conditions may affect device reliability.

Packaging Type

DFN3*3-10

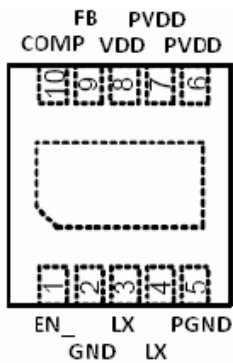

Ordering information

Selection Guide

ACE723 XX + H

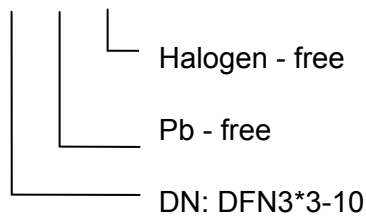

Recommended Work Conditions

Item	Min	Recommended	Max	Unit
Input Voltage Range			5.5	V
Operating Junction Temperature (T _J)	-20		+125	°C

Electrical Characteristics

(VDD=5V, T_A=25°C)

Parameter	Symbol	Conditions	Min	Typ	Max	Units
Input Voltage Range	VDD		2.6		5.5	V
Feedback Voltage	Vref		0.784	0.8	0.816	V
Feedback Leakage current	I _{fb}			0.1	0.4	uA
Quiescent Current	I _q	Active, V _{fb} =0.78, No Switching		450		uA
		Shutdown		1		uA
Line Regulation	LnReg	V _{in} =4V to 5.5V		0.1		%/V
Load Regulation	LdReg	I _{out} =1 to 3A		0.02		%/A
EA Transconductance	G _m			600		us
Switching Rrequency	F _{soc}	R _{en_} =180K		1.35		MHz
PMOS R _{dson}	R _{dsonP}			150		Ω
NMOS R _{dson}	R _{dsonN}			130		Ω
Peak Current Limit	Llimit			3.8		A
EN_Shutdown Voltage	V _{en_}		V _{in} -0.7V		V _{in}	

Efficiency vs. Load Current
(V_{out}=3.3V)

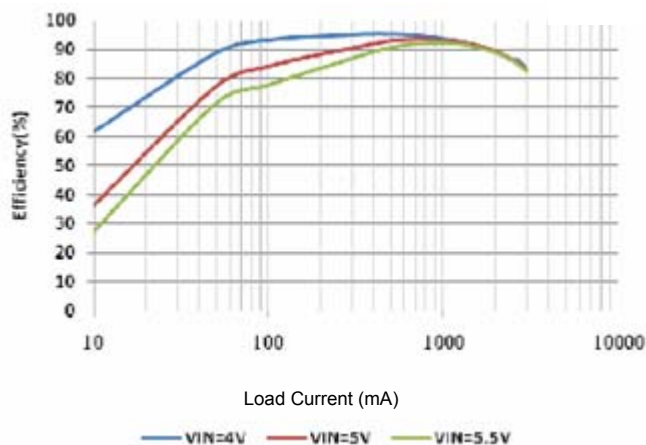

Output Voltage vs. Load Current
(V_{in}=5V)

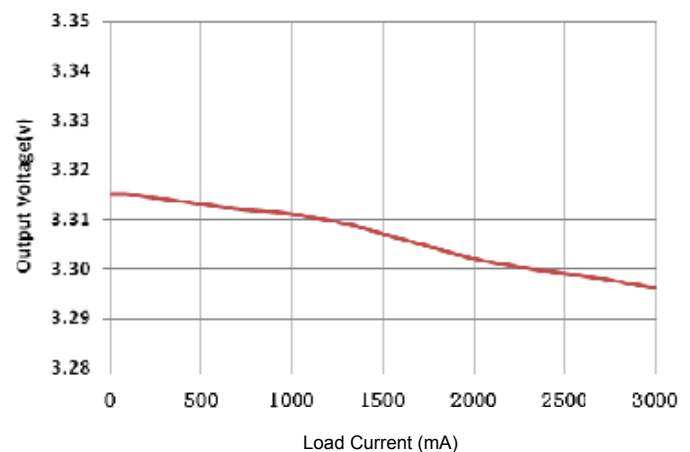

Quiescent Current vs. Input Voltage

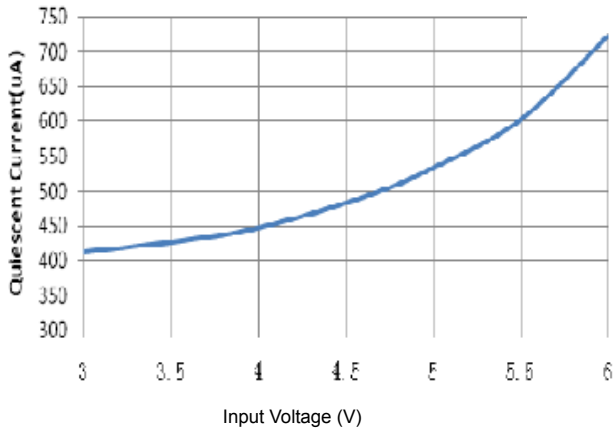

Current Limit vs. Input Voltage

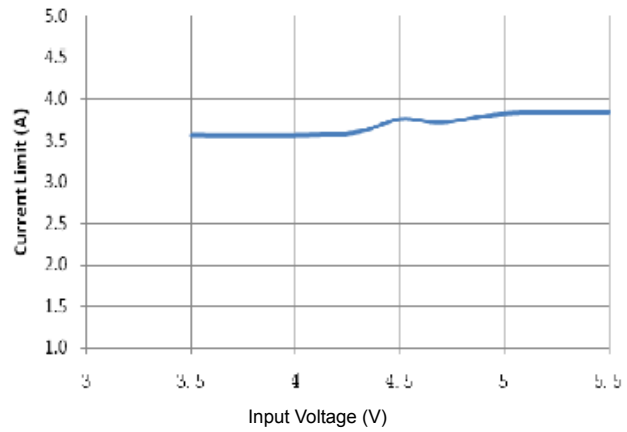

Frequency vs. Temperature
(Vin=5V)

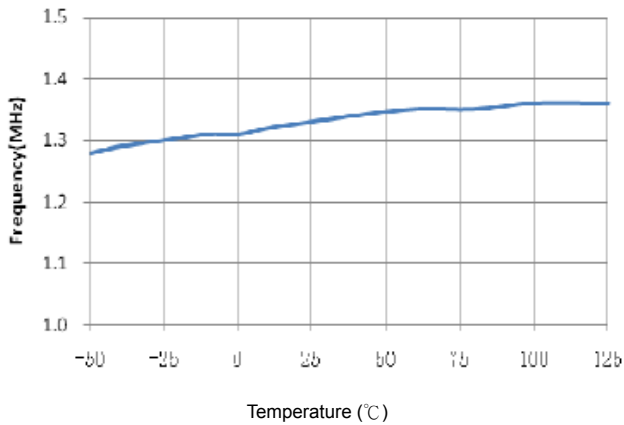

Output Voltage vs. Temperature
(Vin=5V)

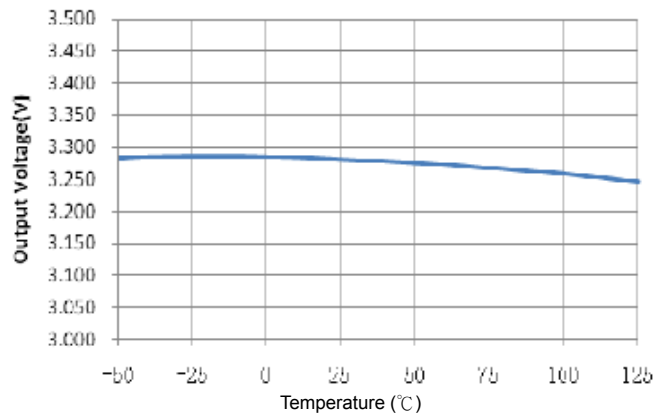

Power On & Soft Start

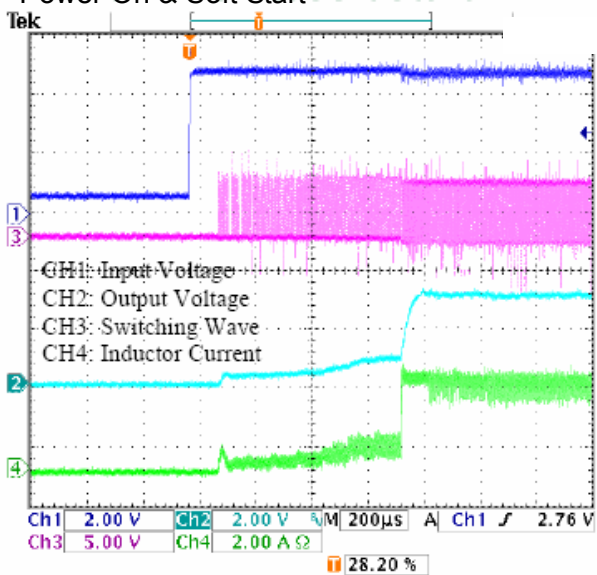

Load Transient Response

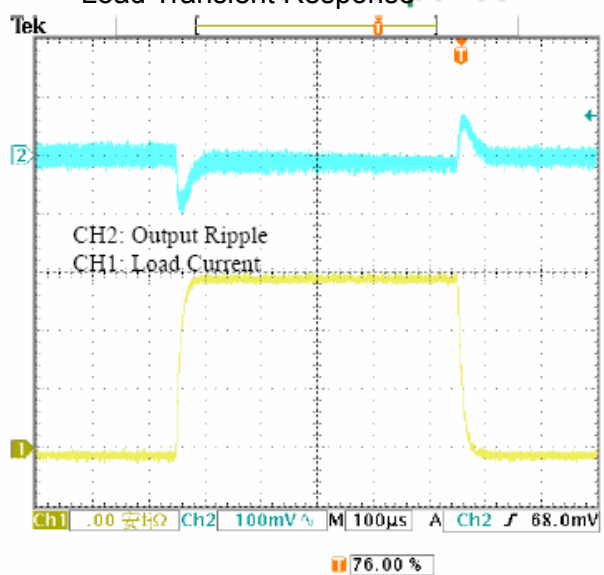

Detailed Description

ACE723 is a 3A synchronous buck, with frequency adjusted by Ren_. It can achieve conversion efficiency up to 95%. It also support 100% duty cycle which will maximize the battery usage. Only a inductor and a few R&C need for peripheral. The PCB size can be very small.

Please note that EN_pin has to be pull high if one wants to shutdown the chip. And release it (with a Ren_connected to GND) to have it work.

Packing Information

DFN3*3-10

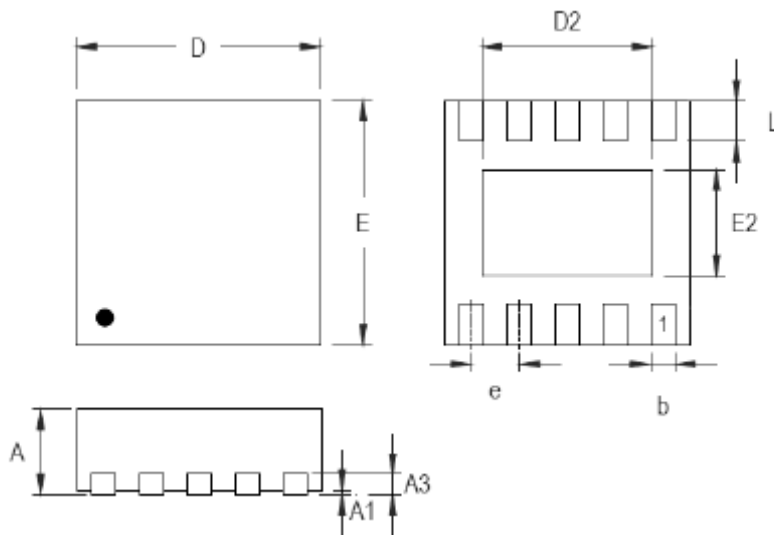

Symbol	Dimensions In Millimeters	
	Min	Max
A	0.700	0.800
A1	0.000	0.050
A3	0.175	0.250
b	0.180	0.300
D	2.950	3.050
D2	2.300	2.650
E	2.950	3.050
E2	1.500	1.750
e	0.500	
L	0.350	0.450

Notes

ACE does not assume any responsibility for use as critical components in life support devices or systems without the express written approval of the president and general counsel of ACE Electronics Co., LTD. As sued herein:

1. Life support devices or systems are devices or systems which, (a) are intended for surgical implant into the body, or (b) support or sustain life, and whose failure to perform when properly used in accordance with instructions for use provided in the labeling, can be reasonably expected to result in a significant injury to the user.
2. A critical component is any component of a life support device or system whose failure to perform can be reasonably expected to cause the failure of the life support device or system, or to affect its safety or effectiveness.